

Series 97

User's Manual



User Levels:

- New User go to page 1.1
- Experienced User go to page 2.1
- Expert User go to page 2.1

Installers:

- Installation go to page 2.1
- Wiring go to page 3.1



1241 Bundy Blvd., P.O. Box 5580, Winona, Minnesota USA 55987-5580
Phone: (507) 454-5300, Fax: (507) 452-4507 <http://www.watlow.com>

NOTE:

Details of a “Note” appear here in the narrow margin on the outside of each page.

CAUTION:

Details of a “Caution” appear here in the narrow margin on the outside of each page.

WARNING:

Details of a “Warning” appear here in the narrow margin on the outside of each page.

Safety Information

We use note, caution and warning symbols throughout this book to draw your attention to important operational and safety information.

A “NOTE” marks a short message in the margin to alert you to an important detail.

A “CAUTION” safety alert appears with information that is important for protecting your equipment and performance. Be especially careful to read and follow all cautions that apply to your application.

A “WARNING” safety alert appears with information that is important for protecting you, others and equipment from damage. Pay very close attention to all warnings that apply to your application.

The safety alert symbol, , (an exclamation point in a triangle) precedes a general CAUTION or WARNING statement.

The electrical hazard symbol, , (a lightning bolt in a triangle) precedes an electric shock hazard CAUTION or WARNING safety statement.

Technical Assistance

If you encounter a problem with your Watlow controller, see the Troubleshooting Table in the Appendix and review all of your configuration information to verify that your selections are consistent with your application: inputs; outputs; alarms; limits; etc. If the problem persists after checking the above, you can get technical assistance from your local Watlow representative, or by dialing (507) 454-5300.

An applications engineer will discuss your application with you.

Please have the following information available when calling:

- Complete model number
- All configuration information
- User’s Manual
- Diagnostic menu readings

Your Feedback

Your comments or suggestions on this manual are welcome. Please send them to: Technical Writer, Watlow Winona, 1241 Bundy Blvd., P.O. Box 5580, Winona, MN 55987-5580; phone: (507) 454-5300; fax: (507) 452-4507. The Series 97 User’s Manual is copyrighted by Watlow Winona, Inc., © July 2005, with all rights reserved. (2194)

T

Series 97 Table of Contents

Chapter 1: Overview	1.1
Chapter 2: Installation	2.1
Chapter 3: Wiring	3.1
Power Wiring	3.3
Sensor Installation Guidelines	3.3
Wiring Example	3.4
Wiring Notes	3.5
Input 1	3.6
Input 2	3.6
Output 1	3.7
Output 2	3.8
Output 3	3.9
Output 4	3.10
Chapter 4: Software Navigation	4.1
Keys and Displays	4.2
Navigation	4.3
Software Map	4.4
Task Charts	4.6
Chapter 5: Features	5.1
Limit	5.2
Input	5.3
Alarms	5.8
Communications	5.11
Chapter 6: Parameters	6.1
Home Page	6.3
Operations Page	6.4
Setup Page	6.7
Factory Page	6.17
Appendix	A.1
Troubleshooting	A.2
Modbus™ RTU	A.4
Calibrating the Series 97	A.11
Glossary	A.14
Specifications	A.18
Ordering Information	A.20
Index	A.21
Prompt Index	A.23
Declaration of Conformity	A.24
Parameter setup order	A.25
Fold out Software Map	A.25 - A.26
Warranty and Returns	back cover

Figures and Tables

Inputs and outputs	1.1
Multiple panel cutout dimensions	2.1
Installing the controller	2.2a
Gap dimensions	2.2b
Removing the controller	2.3
Isolation blocks	3.2
Power wiring	3.3
Wiring example	3.4
Wiring notes	3.5
Input 1 Wiring	
Thermocouple	3.6a
RTD (2- or 3-Wire) 100Ω platinum	3.6b
Input 2 Wiring	
Digital Event	3.6c
Output 1 Limit Output Wiring	
AC Outputs	3.7a
Output 2 Alarm Output Wiring	
AC Outputs	3.8a
Switched DC, Open Collector	3.8b
Output 3 Alarm Wiring	
AC Outputs	3.9
Output 4 wiring	
AC Outputs	3.10a
Communications and Retransmit	3.10b
EIA-232 to EIA-435 Conversion	3.11a
EIA-232 to EIA-485 Converter	3.11b
Keys and displays	4.2
Navigating the Series 97	4.3
Software Map	4.4
Calibration offset	5.3
Filtered and unfiltered input signals	5.4
Sensor ranges	5.5
Event inputs	5.6
Retransmitting a remote set point	5.7
Alarm settings	5.8
Alarm latching	5.9
Alarm silencing	5.10
Parameter setup order	6.2
	inside back cover



About Watlow Winona

Watlow Winona is a division of Watlow Electric Mfg. Co., St. Louis, Missouri, a manufacturer of industrial electric heating products, since 1922. Watlow begins with a full set of specifications and completes an industrial product that is manufactured totally in-house, in the U.S.A.. Watlow products include electric heaters, sensors, controllers and switching devices. The Winona operation has been designing solid state electronic control devices since 1962, and has earned the reputation as an excellent supplier to original equipment manufacturers. These OEMs depend upon Watlow Winona to provide compatibly engineered controls which they can incorporate into their products with confidence. Watlow Winona resides in a 100,000 square foot marketing, engineering and manufacturing facility in Winona, Minnesota.

1

Chapter One Overview

Introduction

Watlow's Series 97 is a microprocessor-based controller with a single input, second auxiliary input and four outputs. Input 1 is used to measure temperature from a thermocouple or RTD sensor. Input 2 can be utilized as a remote reset switch or a hardware lockout switch. With up to four outputs, the controller is versatile in handling applications that require a high/low limit, alarms, retransmit and communications. The controller is so user friendly it can be set up to display safety and limit messages created by the end user to meet the exact application need.

The Series 97 limit controller is added to thermal applications to limit over-temperature conditions. The Series 97 controller provides safety assurance against instances where a high temperature runaway condition could occur from a shorted input sensor or an output device that could fail in a closed position.

The Series 97 is recommended for any application where thermal runaway could result in large product scrap costs, affect operator safety, cause damage to equipment, or create a fire hazard.

The Series 97 is manufactured by ISO 9001-registered Watlow Winona and reliably backed by a three-year warranty.



Figure 1.1 — Series 97 inputs and outputs.

Setup Steps

What to do	How to do it
1 Install the controller.	See Chapter Two.
2 Wire the controller.	See Chapter Three.
3 Configure the controller for your application.	Chapter Four explains the keys, displays and software navigation. Chapter Five explains features, such as alarms and control methods. Chapter Six lists parameter descriptions, ranges, Modbus numbers and other information.
4 Set up communications.	The controller must be equipped for communications, (97__ - ___ U - _____ or 97__ - ___ R - _____). See Chapter Five, Chapter Six and the Appendix.

2

Chapter Two Installation

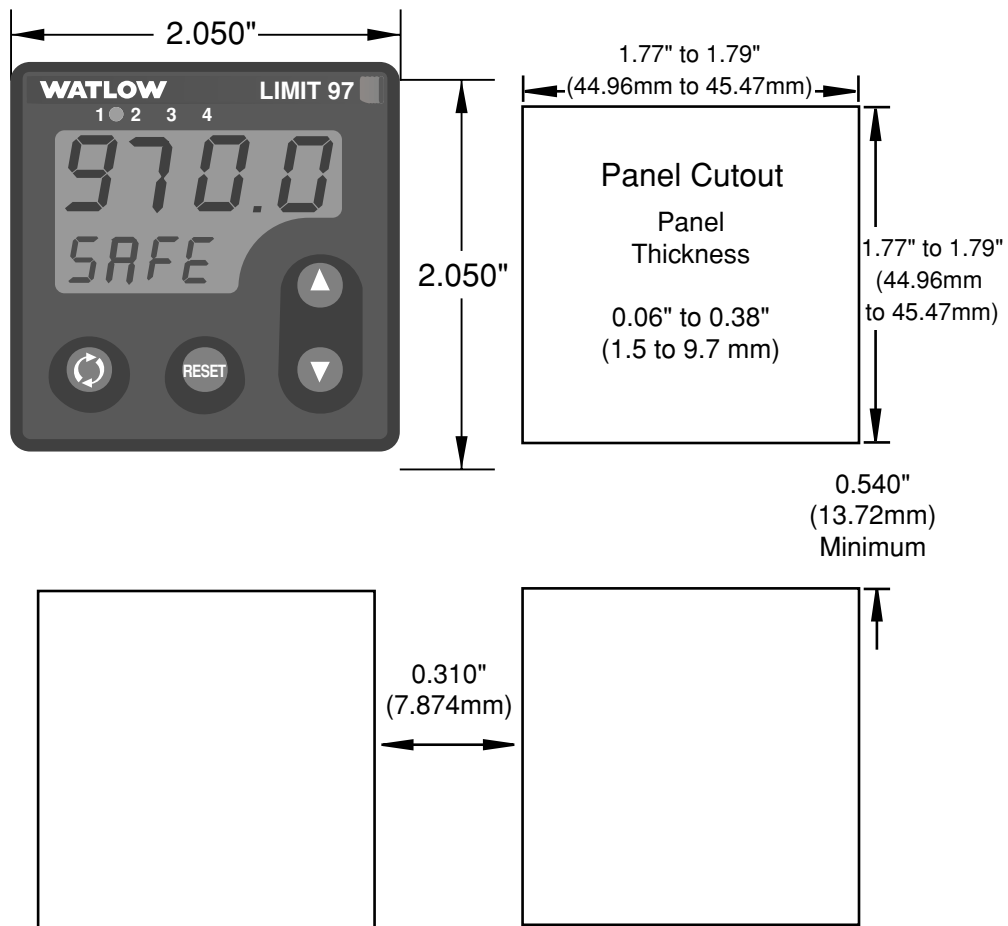

Figure 2.1 - Series 97 multiple panel cutout dimensions.

NOTE: Measurements between panel cutouts are the minimum recommended.

For rapid mounting, use Greenlee 1/16 DIN punch, die, draw stud, part number 60287.

Installing the Series 97 Controller

Installing and mounting requires access to the back of the panel.

1. Make the panel cutout using the tear-out mounting template found on the previous page, or the dimensions found in this chapter.
2. Check to see that the gasket is properly seated into the gasket channel on the front bezel and that it is not twisted. Make sure that the rounded surface of the gasket is the surface that is exposed from the gasket channel, as this is the surface that will mate to the panel surface. Insert the controller into the panel cutout.
3. With the controller inserted into the panel cutout, take the retention collar and slide it over the controller, making certain that the two locating holes in the retention collar are visible from the rear of the controller, with one hole pointing up and one pointing down. Then, take the mounting collar and slide it over the controller, making certain that one cantilever is pointing up and one is pointing down also. With one hand holding the controller and the other hand using a #2 Phillips screw driver, tighten the two screws in the mounting collar until the gap between the bezel and panel surface is .025" maximum. See figure below. Make sure that you cannot move the controller back and forth in the cutout. If you can, you do not have a proper seal.

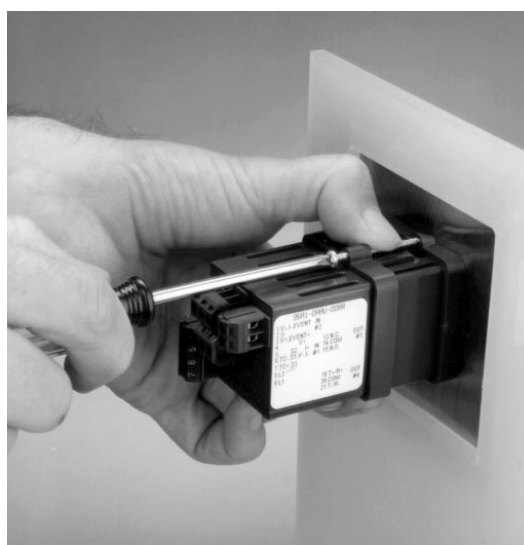

Figure 2.2a - Installing the controller.

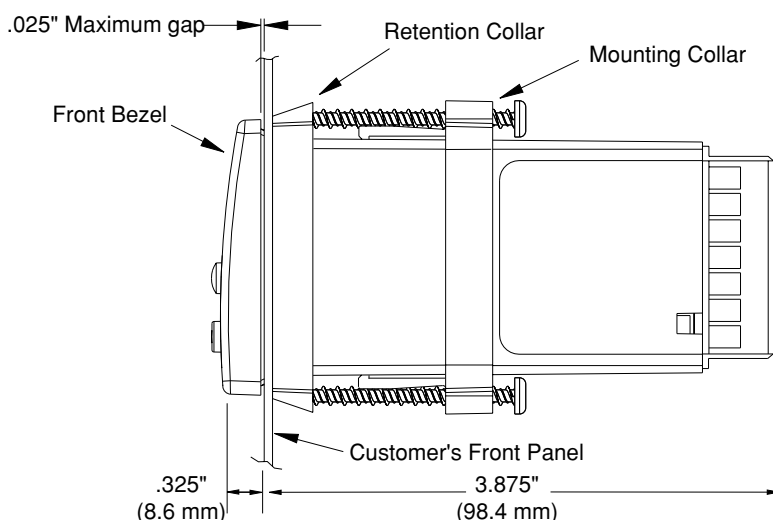

Figure 2.2b - Series 97 gap dimensions.



CAUTION: Follow the installation procedure exactly to guarantee a proper NEMA 4X seal. Make sure the gasket between the panel and the rim of the case is not twisted and is seated properly. Failure to do so could result in damage to equipment.

NOTE: Be careful not to over-tighten the screws. This may cause the mounting cover to fail. Over-tightening occurs when the front bezel is touching the customer's front panel.

Removing the Series 97 Controller

1. Hold the controller with one hand while using the other hand to loosen the screws with a #2 Phillips screwdriver until the end of the screw is flush or past the end of the cantilevers, see the figure below.
2. After the screws have been loosened, hold the controller with one hand while squeezing the two screws together with the other hand. Then simply slide the mounting collar off the controller.

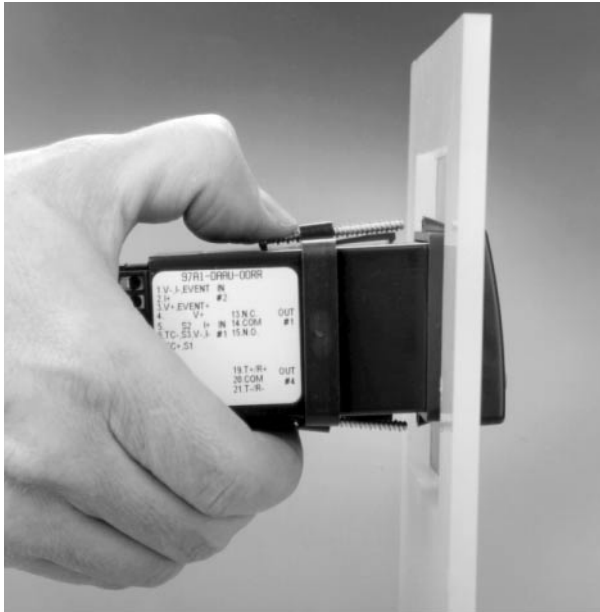

Figure 2.3 - Removing the controller.

Notes

3

Chapter Three Wiring

Power Wiring3.3
Sensor Installation Guidelines3.3
Wiring Example3.4
Wiring Notes3.5
Input 13.6
Input 23.6
Output 1 Limit Output Wiring3.7
Output 2 Alarm Output Wiring3.8
Output 3 Alarm Wiring3.9
Output 43.10
EIA Conversions3.11

Wiring the Series 97

Wiring options depend on the model number. Check the terminal designation stickers on either side of the controller and compare your model number to those shown here and with the model number breakdown on the inside back cover of this manual.

NOTE: Using the Diagnostics Menu (Factory Page) check Output 1 Hardware through Output 4 Hardware, **0EY1** through **0EY4**. See Chapter Six for information about the menu and range of settings for each output. These outputs may differ from those listed for the model number on the controller and described in this manual, indicating a customized hardware setup.

Input-to-output Isolation

The Series 97 uses optical and transformer isolation between the analog inputs and the controller outputs, including the communications interface. This isolation provides a barrier to prevent ground loops when using grounded sensors and/or peripheral equipment.

Here is a breakdown of the isolation barriers:

- Analog inputs 1 and 2 are grouped together.
- Outputs 1 through 4 are grouped together. This does not apply to Output 4 when it is configured for communications.
- If Output 4 is configured for communications, it is isolated from the the other inputs and outputs.



WARNING:

To avoid potential electric shock, use National Electric Code (NEC) safety practices when wiring and connecting this unit to a power source and to electrical sensors or peripheral devices. Failure to do so could result in injury or death.

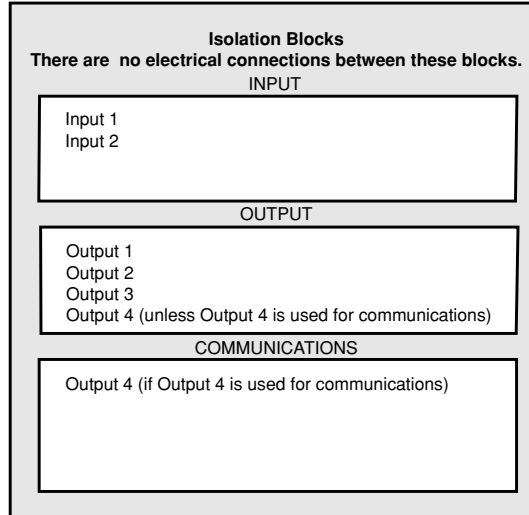

Figure 3.2 — Isolation blocks.

Power Wiring



CAUTION:

If high voltage is applied to a low-voltage unit, irreversible damage will occur.



WARNING:

To avoid damage to property and equipment, and/or injury or loss of life, use National Electric Code (NEC) standard wiring practices to install and operate the Series 97. Failure to do so could result in such damage, and/or injury or death.



CAUTION:

Maintain isolation between input 1 and input 2 to prevent a ground loop. A ground loop may cause incorrect readings, dashes across the upper display or the display of error codes. Failure to follow this guideline could result in damage to equipment.

100 to 240V~ (ac), nominal (85 to 264 actual) 97 A _ _ _ _ _
 24 to 28V≈ (ac/dc), nominal (21 to 30 actual) 97 B _ _ _ _ _

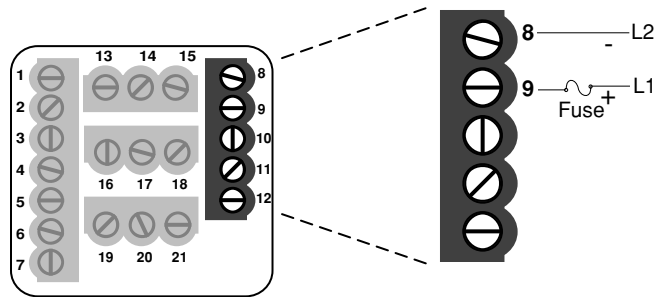

Figure 3.3 - Power wiring.

Sensor Installation Guidelines

Thermocouple inputs: Extension wire for thermocouples must be of the same alloy as the thermocouple to limit errors.

When using a voltage input for the digital event on Input 2, use an ungrounded thermocouple on Input 1. If a grounded thermocouple is required, the signal to input 2 must be isolated to prevent possible ground loops.

RTD input: Each 1Ω of lead wire resistance can cause a +2°F error when using a two-wire RTD. A three-wire RTD sensor overcomes this problem. All three wires must have the same electrical resistance (i.e., same gauge, same length, multi-stranded or solid, same metal).

Wiring Example



WARNING:

To avoid potential electric shock and damage to property and equipment, use National Electric Code (NEC) safety practices when wiring and connecting this unit to a power source and to electrical sensors or peripheral devices. Failure to do so could result in injury or death.

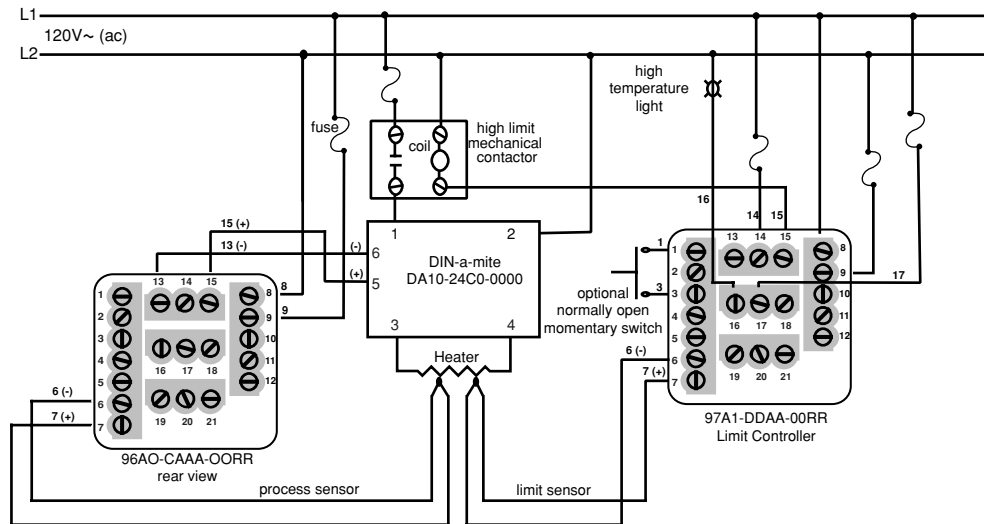

WARNING:

Install high or low temperature limit control protection in systems where an over temperature fault condition could present a fire hazard or other hazard. Failure to install temperature limit control protection where a potential hazard exists could result in damage to equipment, property and injury to personnel.

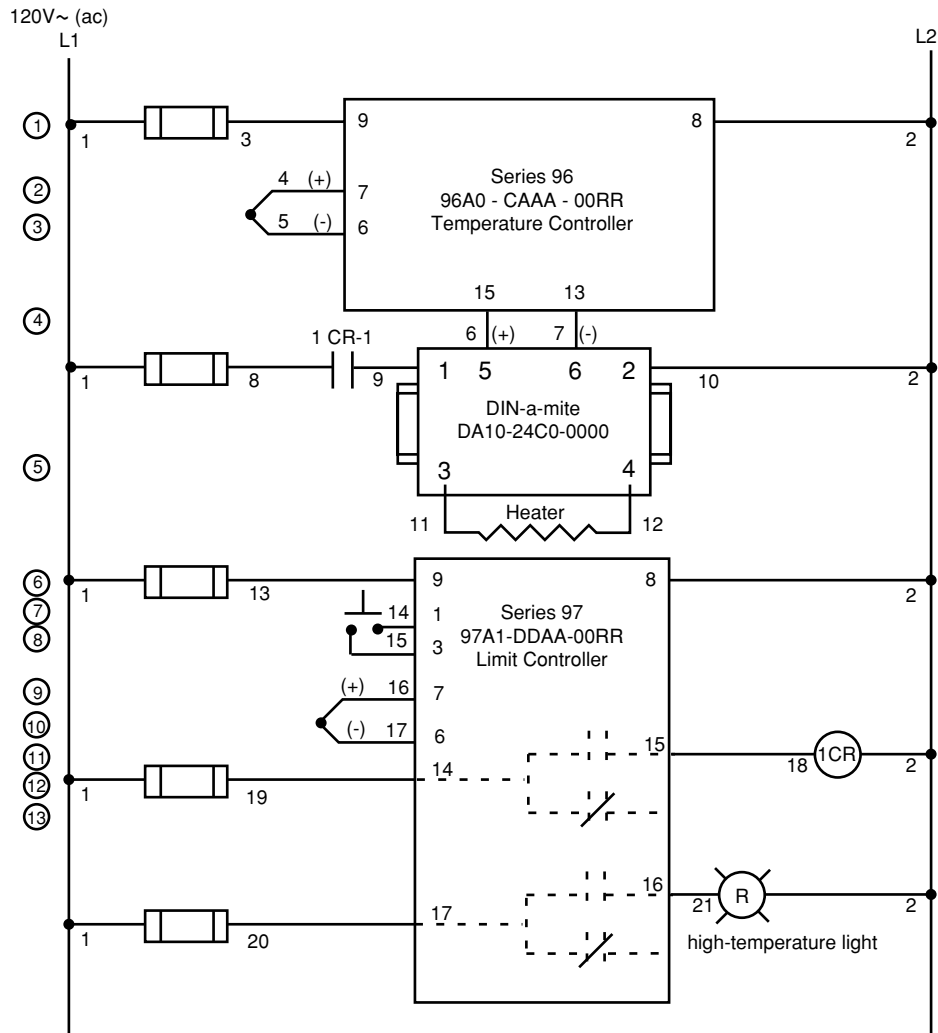
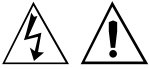

Figure 3.4 - System wiring example.

Wiring Notes



WARNING:

To avoid damage to property and equipment, and/or injury or loss of life, use National Electric Code (NEC) standard wiring practices to install and operate the Series 97. Failure to do so could result in such damage, and/or injury or death.

Sketch in your application on this page or a copy of it. See the wiring example in this chapter.

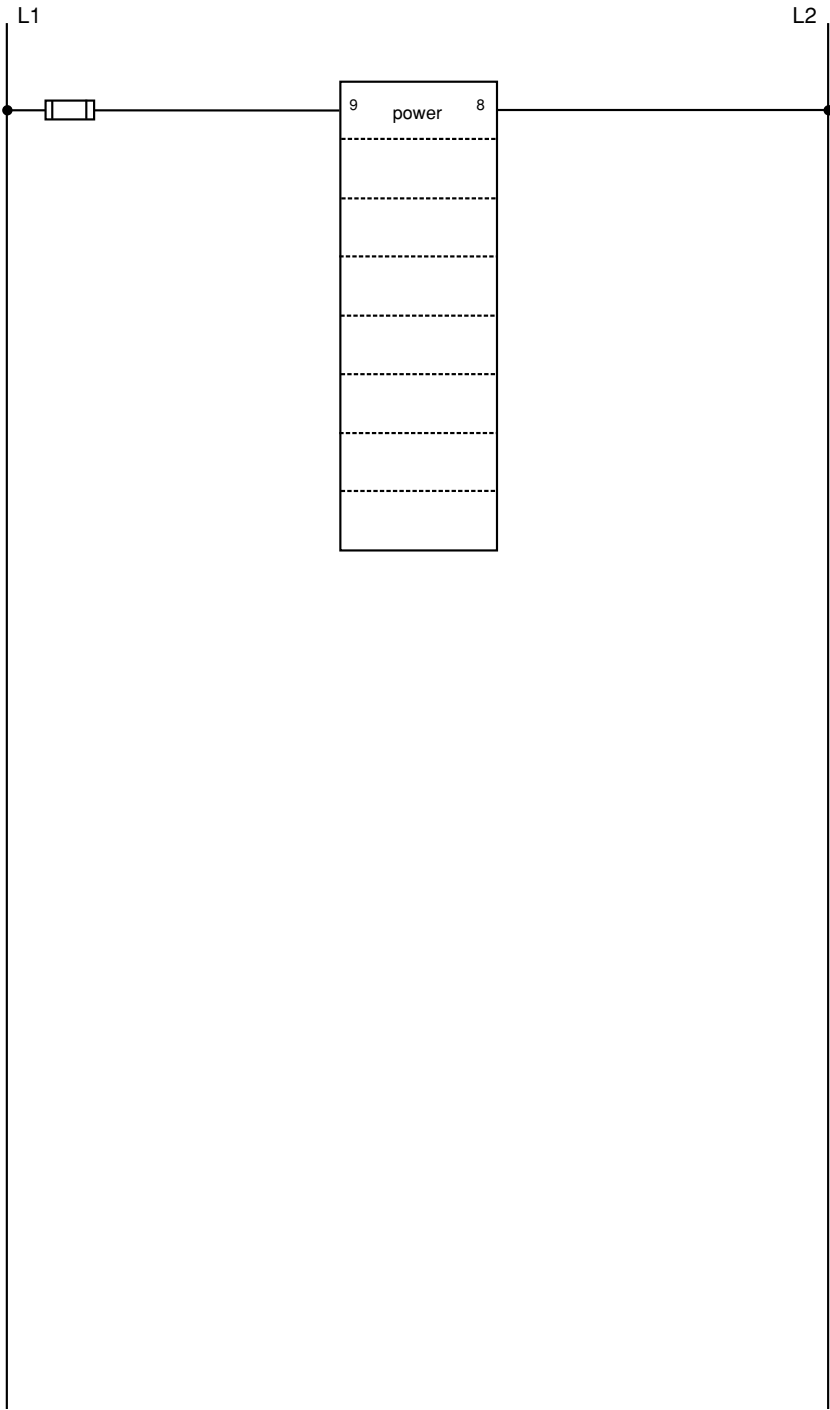

Figure 3.5 - Wiring notes.

Input 1 Wiring

NOTE:

Successful installation requires five steps:

- Choose the controller's hardware configuration and model number (Appendix);
- Choose a sensor (Chapters 3 and 6, and Appendix);
- Install the controller (Chapter 2);
- Wire the controller (Chapter 3) and
- Configure the controller (Chapters 4, 5 and 6).



WARNING:

To avoid damage to property and equipment, and/or injury or loss of life, use National Electric Code (NEC) standard wiring practices to install and operate the Series 97. Failure to do so could result in such damage, and/or injury or death.



CAUTION:

Maintain isolation between input 1 and input 2 to prevent a ground loop. A ground loop may cause incorrect readings, dashes across the upper display or the display of error codes. Failure to follow this guideline could result in damage to equipment and product.

Figure 3.6a – Thermocouple

Available on all units
Impedance: 20MΩ

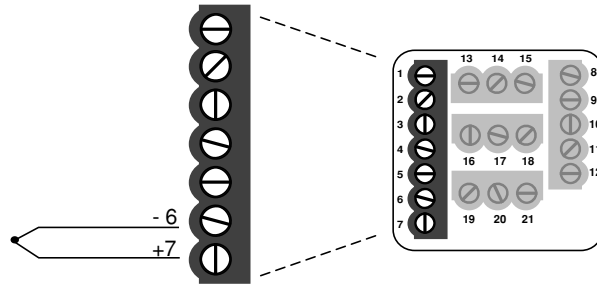
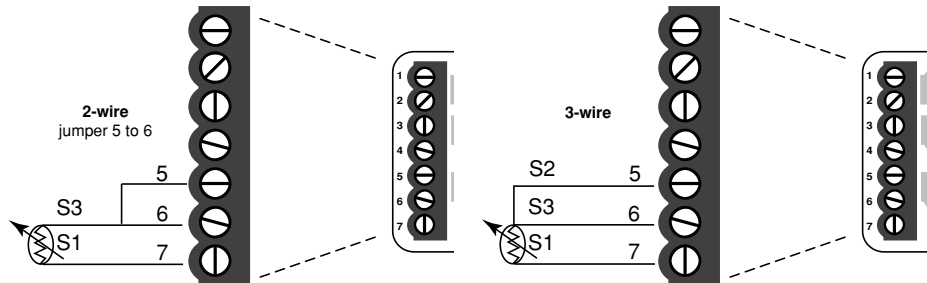

Figure 3.6b – RTD (2- or 3-Wire) 100Ω Platinum

Available on all units



Input 2 Wiring

Figure 3.6c – Digital Event

97 _ 1 - - - - -

Voltage input

3-36V_{DC} (dc) Event Input High State

0-2V_{DC} (dc) Event Input Low State

Contact closure

0-2kΩ Event Input Low State

> 23kΩ Event Input High State

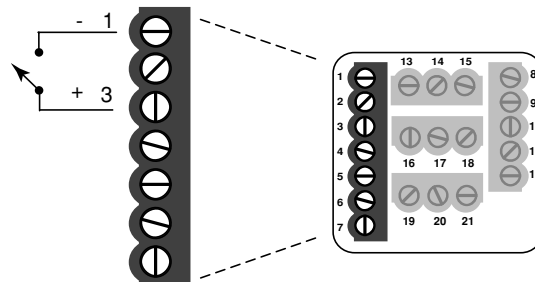
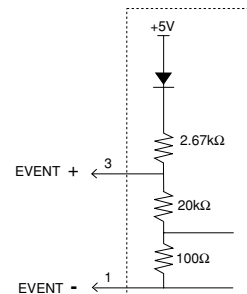

Output 1 Limit Output Wiring

NOTE:

Successful installation requires five steps:

- Choose the controller's hardware configuration and model number (Appendix);
- Choose a sensor (Chapters 3 and 6, and Appendix);
- Install the controller (Chapter 2);
- Wire the controller (Chapter 3) and
- Configure the controller (Chapters 4, 5 and 6).



WARNING:

To avoid damage to property and equipment, and/or injury or loss of life, use National Electric Code (NEC) standard wiring practices to install and operate the Series 97. Failure to do so could result in such damage, and/or injury or death.

NOTE:

Switching inductive loads (relay coils, solenoids, etc.) with the mechanical relay, switched dc or solid-state relay output options requires use of an R.C. suppressor.

Watlow carries the R.C. suppressor Quencharc brand name, which is a trademark of ITW Pakron. Watlow Part No. 0804-0147-0000.

Figure 3.7a – AC Outputs

- Electromechanical Relay without contact suppression
97 __ - D ____ - ____
Form C, 2 amps, off-state impedance: 31M Ω

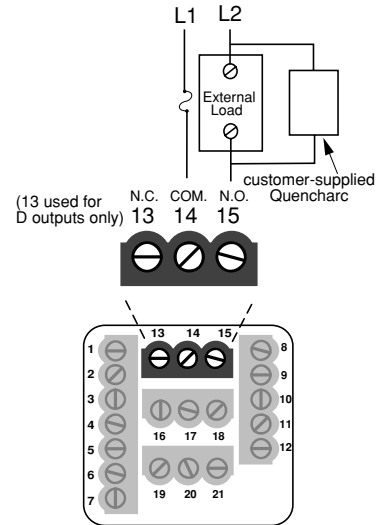

Output 2 Alarm Output Wiring

NOTE:

Successful installation requires five steps:

- Choose the controller's hardware configuration and model number (Appendix);
- Choose a sensor (Chapters 3 and 6, and Appendix);
- Install the controller (Chapter 2);
- Wire the controller (Chapter 3) and
- Configure the controller (Chapters 4, 5 and 6).

NOTE:

Switching inductive loads (relay coils, solenoids, etc.) with the mechanical relay, switched dc or solid-state relay output options requires use of an R.C. suppressor.

Watlow carries the R.C. suppressor Quencharc brand name, which is a trademark of ITW Pakron. Watlow Part No. 0804-0147-0000.



WARNING:

To avoid damage to property and equipment, and/or injury or loss of life, use National Electric Code (NEC) standard wiring practices to install and operate the Series 97. Failure to do so could result in such damage, and/or injury or death.

Figure 3.8a – AC Outputs

- Electromechanical relay without contact suppression

97 _ _ _ D _ _ _ _ _

Form C, 2 amps, off-state impedance: 31MΩ

- Solid-state relay without contact suppression

97 _ _ _ K _ _ _ _ _

0.5 amps, off-state impedance: 31MΩ

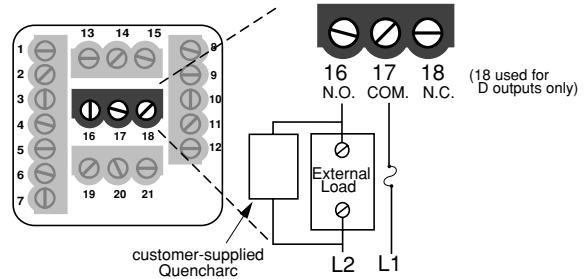

Figure 3.8b – Switched DC, Open Collector

97 _ _ _ C _ _ _ _ _

Switched DC configuration:

Maximum voltage: 28V_{DC}

Maximum current: 30mA

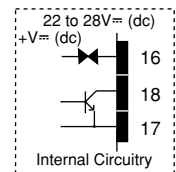
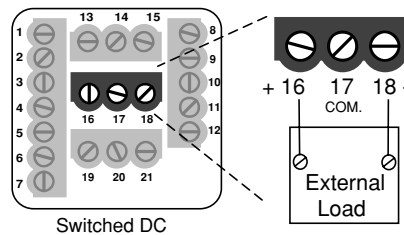

Open collector configuration:

Maximum voltage: 42V_{DC}

Maximum current: 200 mA

Output 3 Alarm Wiring

NOTE:

Successful installation requires five steps:

- Choose the controller's hardware configuration and model number (Appendix);
- Choose a sensor (Chapters 3 and 6, and Appendix);
- Install the controller (Chapter 2);
- Wire the controller (Chapter 3) and
- Configure the controller (Chapters 4, 5 and 6).

NOTE:

Switching inductive loads (relay coils, solenoids, etc.) with the mechanical relay, switched dc or solid-state relay output options requires use of an R.C. suppressor.

Watlow carries the R.C. suppressor Quencharc brand name, which is a trademark of ITW Pakron. Watlow Part No. 0804-0147-0000.



WARNING:

To avoid damage to property and equipment, and/or injury or loss of life, use National Electric Code (NEC) standard wiring practices to install and operate the Series 97. Failure to do so could result in such damage, and/or injury or death.

Figure 3.9 – AC Outputs

Electromechanical Relay without Contact Suppression

97 _ _ _ _ D _ _ _ _ _

Form C, 2 amps, off-state impedance: 31MΩ

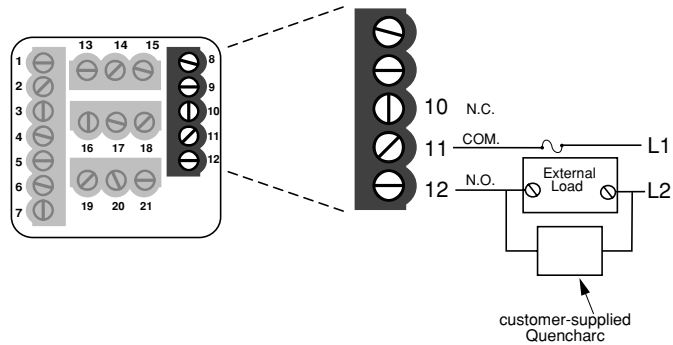

Output 4 Wiring

NOTE:

Successful installation requires five steps:

- Choose the controller's hardware configuration and model number (Appendix);
- Choose a sensor (Chapters 3 and 6, and Appendix);
- Install the controller (Chapter 2);
- Wire the controller (Chapter 3) and
- Configure the controller (Chapters 4, 5 and 6).

NOTE:

Switching inductive loads (relay coils, solenoids, etc.) with the mechanical relay, switched dc or solid-state relay output options requires use of an R.C. suppressor.

Watlow carries the R.C. suppressor Quencharc brand name, which is a trademark of ITW Pakron. Watlow Part No. 0804-0147-0000.



WARNING:

To avoid damage to property and equipment, and/or injury or loss of life, use National Electric Code (NEC) standard wiring practices to install and operate the Series 97. Failure to do so could result in such damage, and/or injury or death.

Figure 3.10a – AC Outputs

Electromechanical Relay without Contact Suppression

97 _ _ _ _ _ D _ _ _ _ _

Form C, 2 amps, off-state impedance: 31MΩ

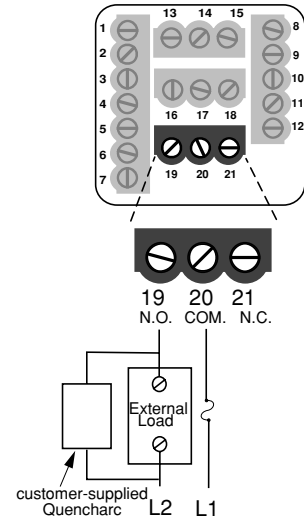

Figure 3.10b – Communications and Retransmit Option

EIA/TIA-232

EIA/TIA-485

Retransmit Option

97 _ _ _ _ _ R _ _ _ _ _

97 _ _ _ _ _ U _ _ _ _ _

97 _ _ _ _ _ M _ _ _ _ _

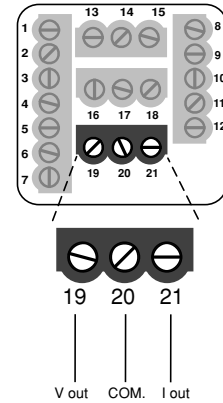
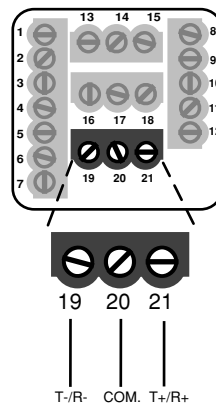
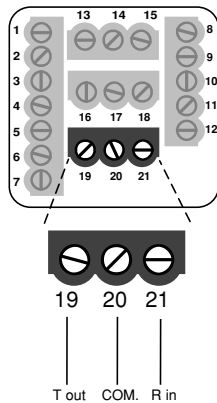

NOTE: For more information about communicating with Watlow controllers, go to www.watlow.com and download the Data Communications Reference: Electronic User's Manual. It is located under Literature, User's Manuals, English and search on *data communications reference*.

NOTE:

Successful installation requires five steps:

- Choose the controller's hardware configuration and model number (Appendix);
- Choose a sensor (Chapters 3 and 6, and Appendix);
- Install the controller (Chapter 2);
- Wire the controller (Chapter 3) and
- Configure the controller (Chapters 4, 5 and 6).

Figure 3.11a — EIA-232 to EIA-485 Conversion

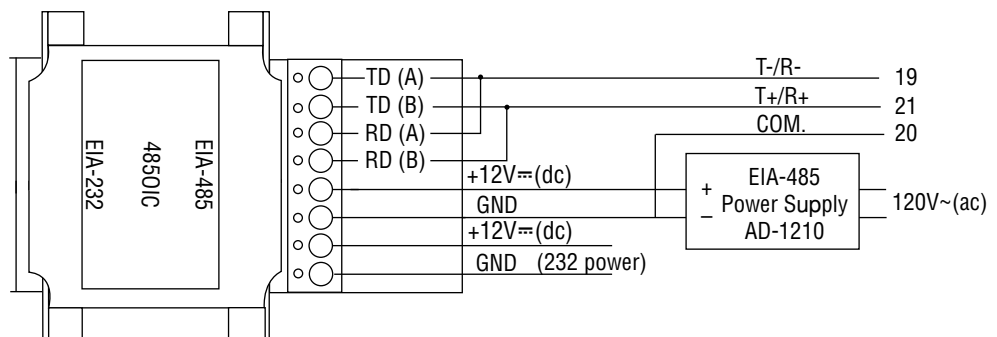

B&B Converter (B&B Electronics Manufacturing Company, (815) 433-5100).

NOTE:

The CMC converter requires an external power supply when used with a laptop computer.



WARNING:

To avoid damage to property and equipment, and/or injury or loss of life, use National Electric Code (NEC) standard wiring practices to install and operate the Series 97. Failure to do so could result in such damage, and/or injury or death.

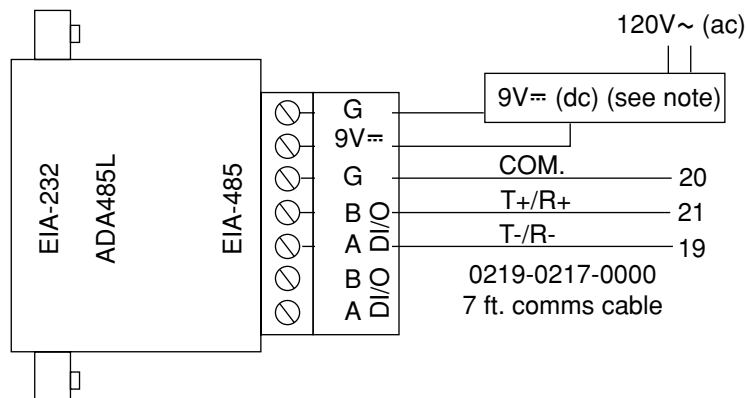

CMC Converter (CMC Connecticut Micro-Computer, Inc., 800-426-2872).

Figure 3.11b — Termination for EIA-232 to EIA-485 Converter

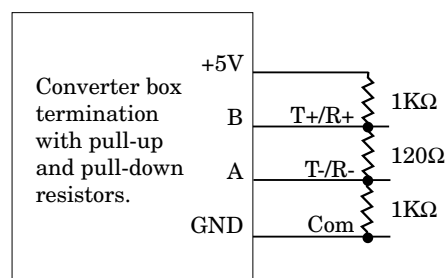

NOTE:

If the system does not work properly, it may need termination resistors at each end of the network. A typical installation would require a 120-ohm resistor across the transmit/receive terminals (19 and 21) of the last controller in the network and the converter box or serial card. Pull-up and pull-down resistors may be needed to maintain the correct voltage during the idle state.

Notes

4

Chapter Four Navigation and Software



Keys and Displays	4.2
Navigation	4.3
Software Map	4.4
Task Charts	4.6

Keys and Displays

This chapter explains keys, displays and navigation skills, and presents charts showing how to accomplish basic and advanced tasks. You'll also find a complete software map.

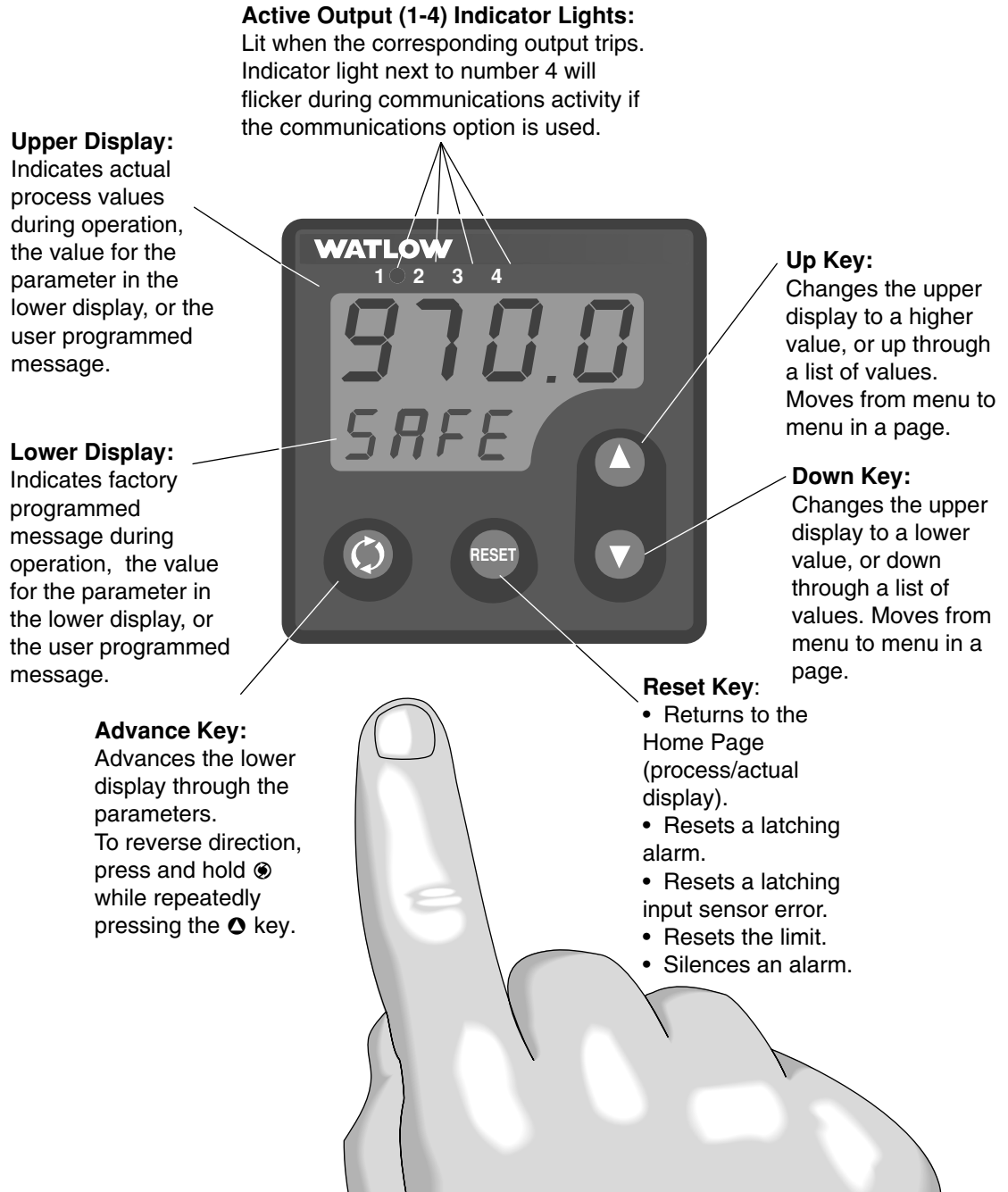

Figure 4.2 — Series 97 keys and displays.

Navigating the Series 97

Choose a page (Operations, Setup or Factory) and press its key sequence. The page appears in the lower display.



- **Operations Page:** press and keys together for three seconds.



- **Setup Page:** press and keys together for six seconds.



- **Factory Page:** press and keys together for six seconds.



- **Home Page:** From anywhere, press the Reset Key.

Figure 4.3 — Navigating the Series 97.

Press or to find a specific menu in a page. The menu appears in the upper display and the page remains in the lower display.

Press to enter the list of parameters in the menu displayed. The menu's parameters appear in the lower display and the values in the upper. To go backward through the parameter list press and together.

Press or to select a value, either alpha or numeric.

Press to set the value and go to the next parameter.

Navigation

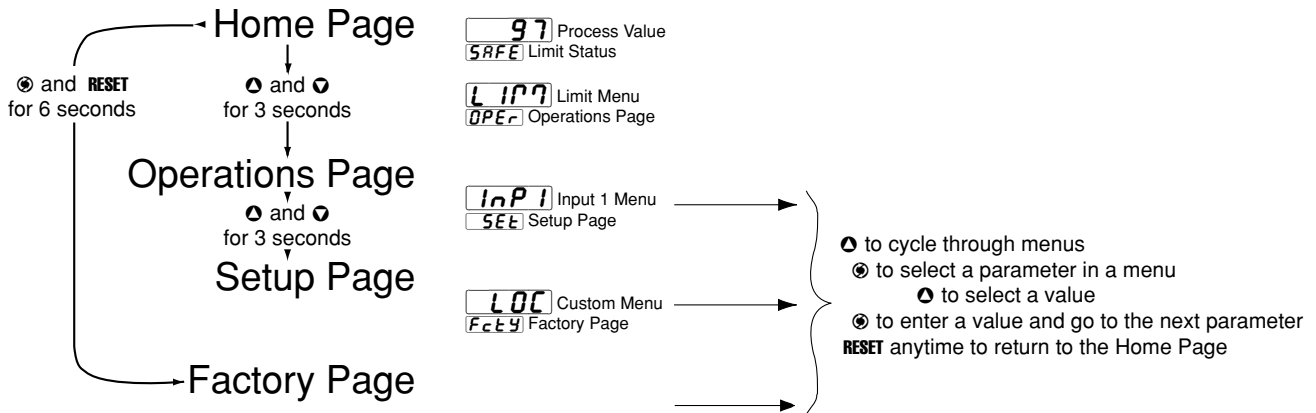

Software Map

Home Page

97 Process Value
 SAFE Limit Status

Operations Page

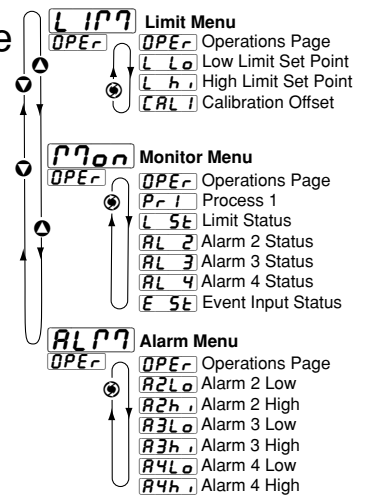
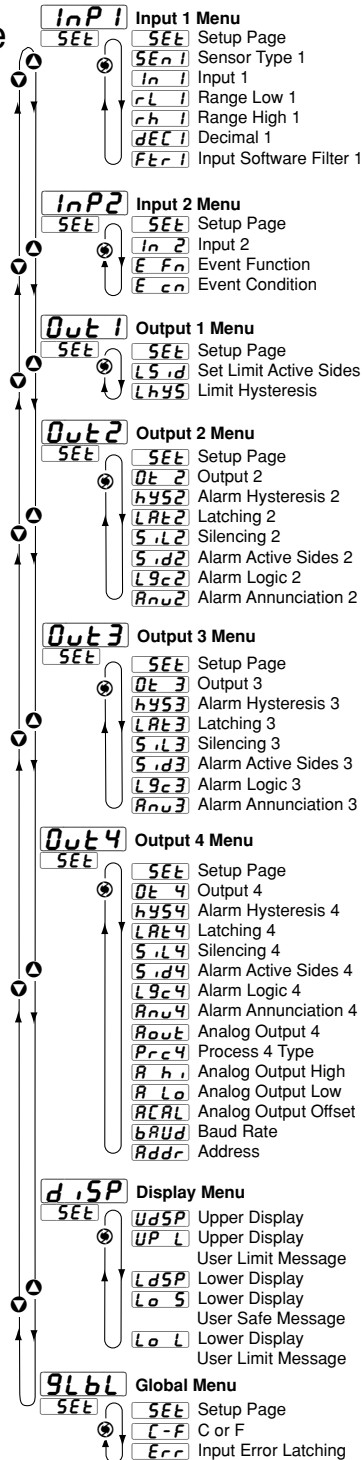
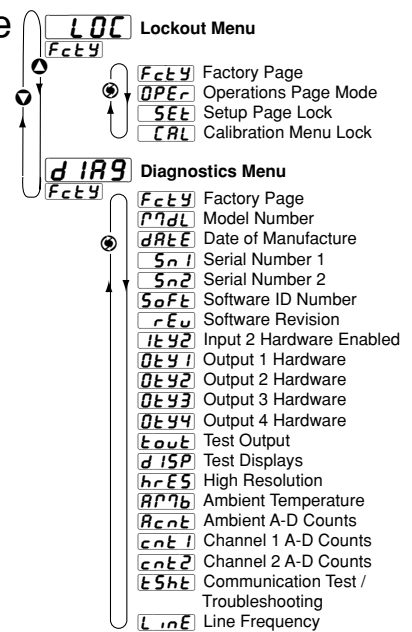

Figure 4.4 — Software Map.

Setup Page



Factory Page



Note: The Factory Page also includes calibration parameters that are not necessary for everyday use of the controller. Calibration parameters and procedures are explained in the Appendix.





Tip: Use the software map on the inside back cover for easy reference.

Basic navigation for new users

Use this example task to learn how to use the keys and displays. Navigation skills are essential for setting up the controller. For more information about the control features available in the Series 97, see Chapter Five. For a table of all parameters and values, see Chapter Six.

Configure the controller

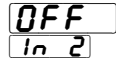
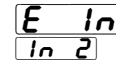
To configure the controller to suit your application, go to the Setup Page, enter the menus and set the parameters for the system, its inputs and outputs.

Do this	Press these keys	You'll see*
1 Go to the Setup Page from the Home Page.	▲Up-arrow and ▼Down-arrow keys for 6 seconds.	After three seconds the Operations Page appears in the lower display; after six seconds the Setup Page appears in the lower display. A menu is in the upper display. 
2 Select a menu to enter.	▲Up-arrow key.	The Setup Page remains in the lower display while menu names appear in the upper display. 
3 Go to a parameter.	⏸Advance key.	The menu's parameters appear in the lower display and the values appear in the upper display.  (Note: When you enter a menu, the display changes. Instead of the Setup Page and menu, you see parameter and value.)
4 Choose a value.	▲Up-arrow key, until you reach the desired value.	Values appear in the upper display when the parameter is in the lower display. 
5 Set a value and go on to the next parameter.	⏸Advance key (when the chosen value is displayed).	You will see the chosen value in the upper display. After pressing the Advance key, the next parameter appears in the lower display, with one of its values in the upper display. Values auto-enter after five seconds. 
Summary	To make a selection or choice: To move or change location in a page or menu:	Press ▲Up-arrow key or ▼Down-arrow key. Press ⏸Advance key or Reset Key.

*What you see depends on the options included in your controller.

5

Chapter Five Features

Limit	5.2
Input	
Calibration Offset	5.3
Filter Time Constant	5.4
Sensor Selection	5.5
Range Low and Range High	5.5
Event Input	5.6
Retransmitting the process value ...	5.7
Alarms	
Alarm Set Points	5.8
Alarm Hysteresis	5.8
Process or Deviation Alarms	5.9
Alarm Latching	5.9
Alarm Silencing	5.10
Communications	
Overview	5.11

Limit

The Series 97 limit controller is added to thermal applications to limit over- or under-temperature conditions. The Series 97 controller provides safety assurance against instances where a high temperature runaway condition could occur from a shorted input sensor or an output device that could fail in a closed position. A limit condition is latched and therefore requires operator intervention to clear it. This is done by pressing the Reset key after the limit condition has passed.

The Series 97 is recommended for any application where thermal runaway could result in large product scrap costs, affect operator safety, cause damage to equipment or create a fire hazard.

Input

Calibration Offset

Calibration offset allows a device to compensate for an inaccurate sensor, lead resistance or other factors that affect the input value. A positive offset increases the input value, and a negative offset decreases the input value.

The input 1 offset value can be viewed or changed with Calibration Offset 1 **CAL 1** (Limit Menu).

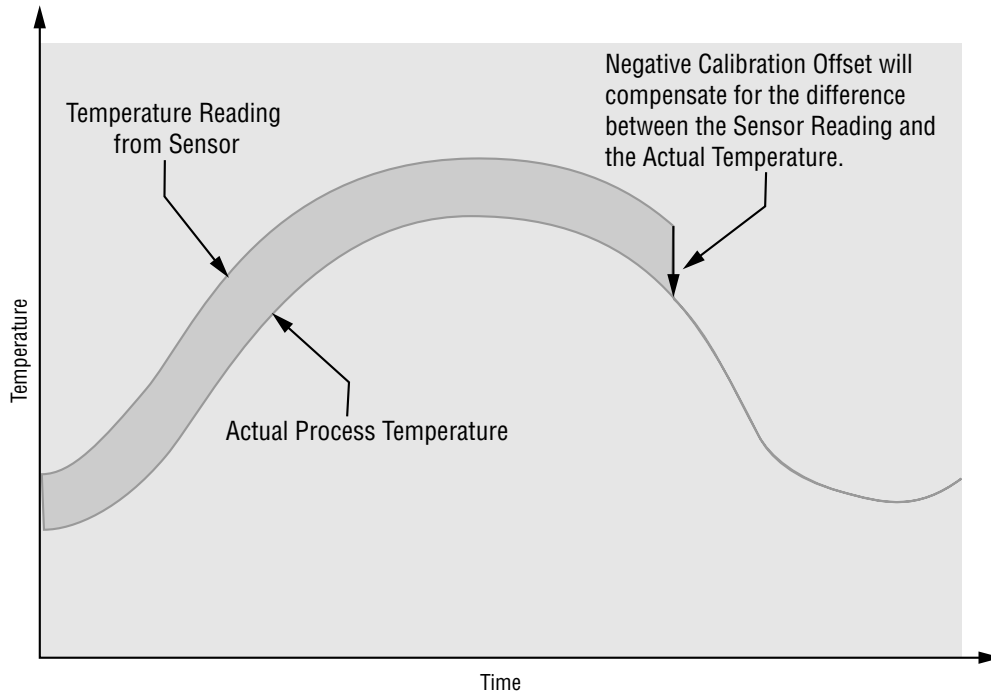

Figure 5.3 — Calibration offset.

Filter Time Constant

A time filter smooths an input signal by applying a first-order filter time constant to the signal. Either the displayed value or both the displayed and control values can be filtered. Filtering the displayed value makes it easier to monitor.

View or change the input 1 time filter with Filter Time Constant 1 **[F t r 1]** (Input 1 Menu). A positive value affects only the viewed values. A negative value affects both the viewed and control values.

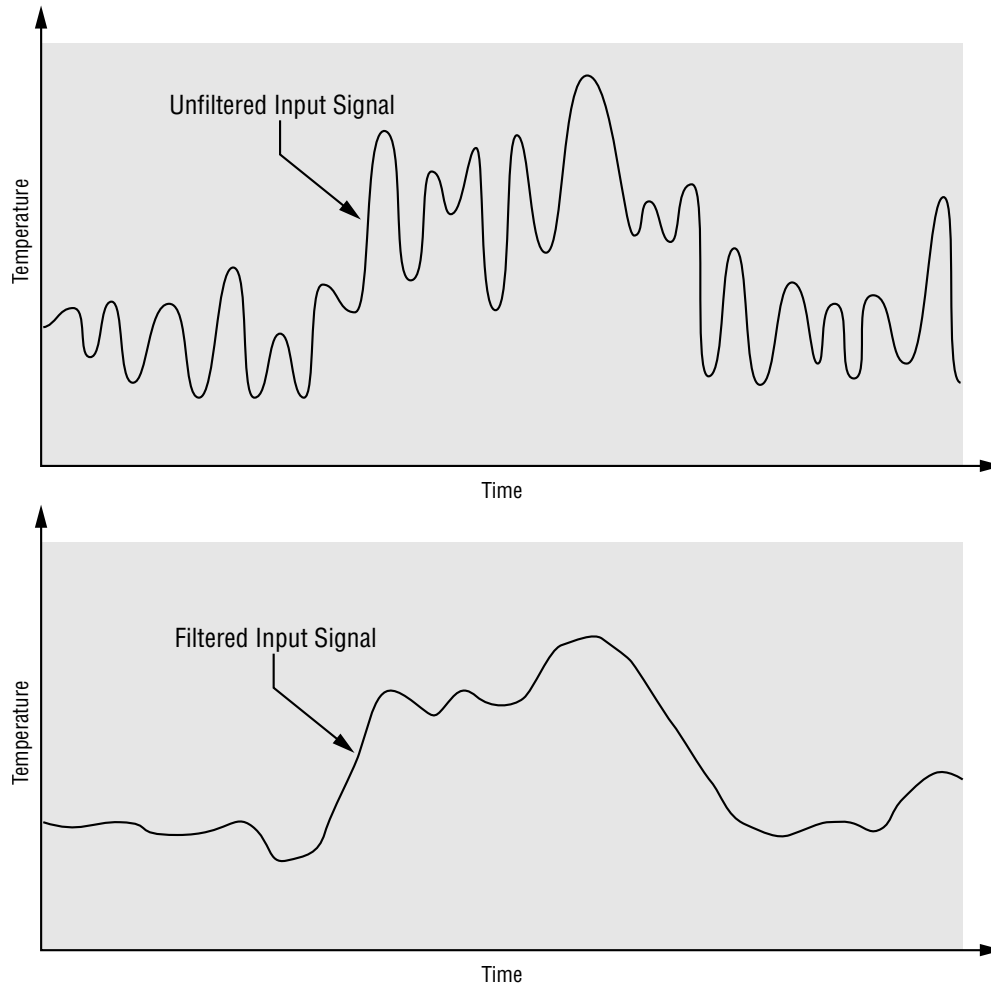

Figure 5.4 — Filtered and unfiltered input signals.

Sensor Selection

You need to configure a controller to match the input device, which is normally a thermocouple or RTD. When you select an input device the controller automatically sets the input linearization to match the sensor. It also sets high and low limits, which in turn limit the range high and range low values.

Use Sensor Type 1 `[SEn1]` and Input 1 `[In1]` (Input 1 Menu) to select the appropriate sensor for input 1.

Range Low and Range High

The controller constrains the set point to a value between range high and range low. Range high cannot be set higher than the sensor high limit or lower than range low. Range low cannot be set lower than the sensor low limit or higher than range high.

Use Range Low 1 `[rL1]` and Range High 1 `[rH1]` (Input 1 Menu) to select or view values for the corresponding input 1 parameters.

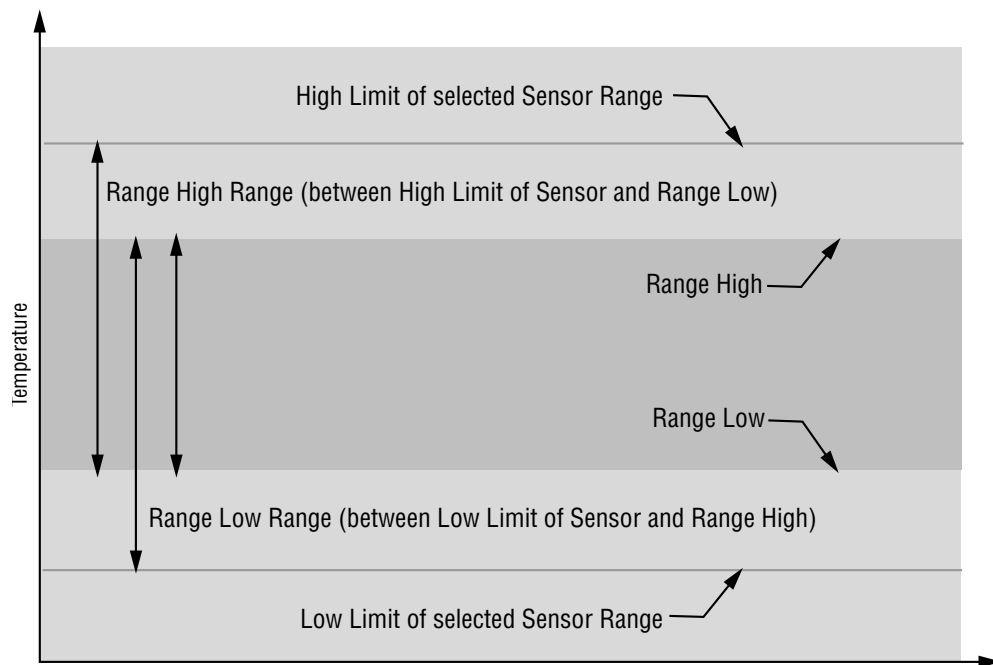

Figure 5.5 — Sensor ranges.

Event Input

With an event input an operator can perform certain operations on a system by opening or closing a switch or applying a dc logic signal to the controller. This feature can add convenience, safety or security to a system.

Use Event Input Status **E St** (Monitor Menu) to read the state of the event input parameter.

Use Event Function **E Fn** (Input 2 Menu) to select how an event will affect the system.

nonE Events will not affect the system.

LrSE Clear Limit.

L0C Lock out key board.

ALr Clear an alarm.

Use Event Condition **E cn** (Input 2 Menu) to select what condition will trigger an event.

Lo Low generates an event while the voltage is low (switch closed).

h, High generates an event while the voltage is high (switch open).

r,SE Rise changes the event state when the voltage changes from low to high.

FALL Fall changes the event state when the voltage changes from high to low.

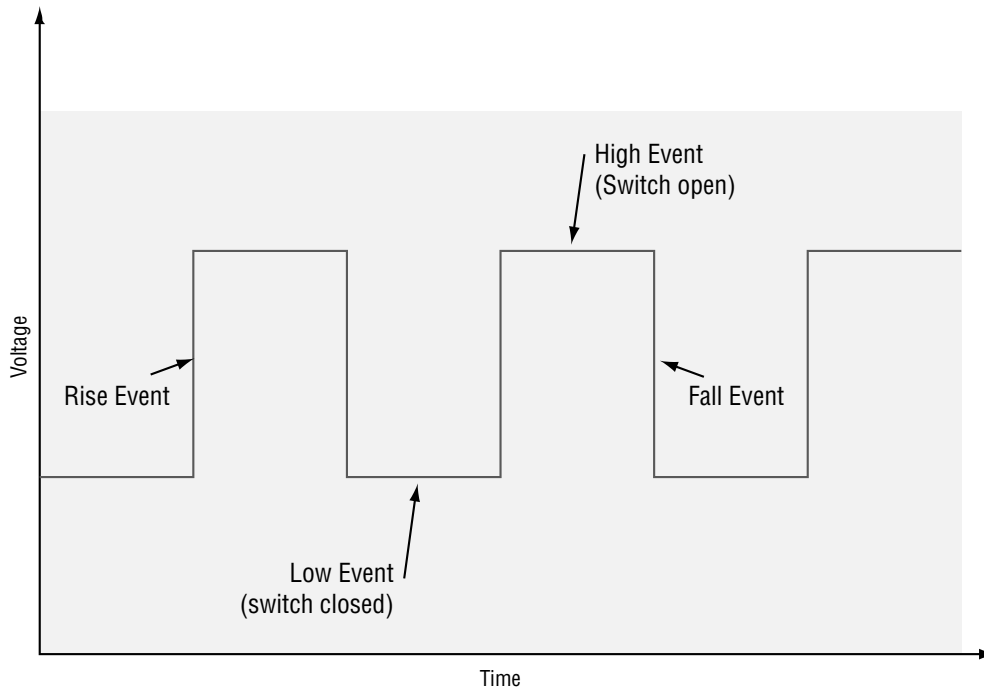

Figure 5.6 — Event inputs.

Retransmit

The retransmit output can be used to transmit an analog signal representing the value of the input process variable. The retransmit signal can be configured as either a milliamp or a voltage signal. In choosing the type of retransmit signal the operator must take into account the input impedance of the external device and the required signal type, either voltage or milliamps.

A typical application might use the retransmit option to record a process value with a chart recorder.

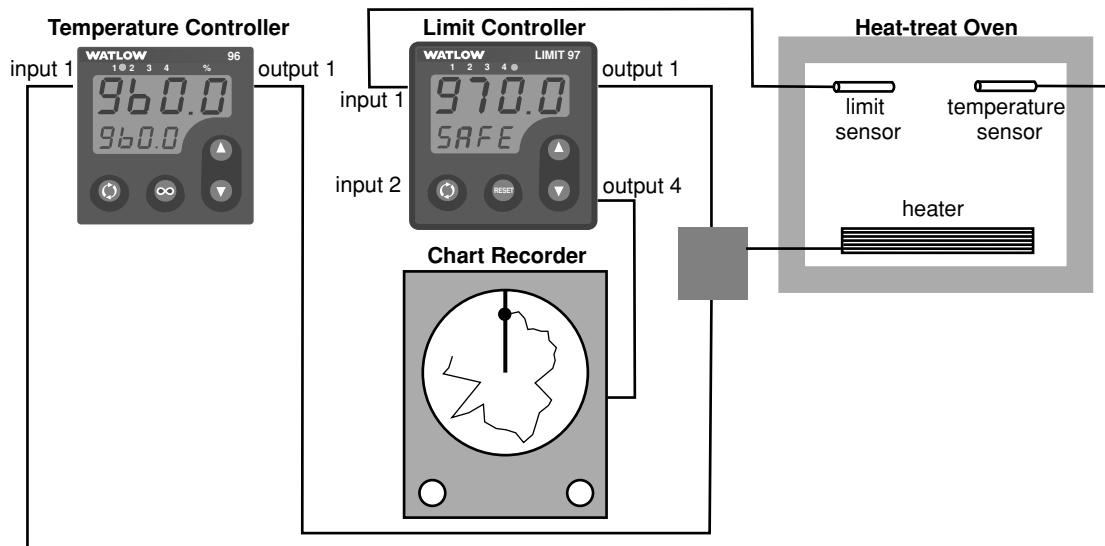

Figure 5.7 — Retransmit example.

In the example a Series 96 is being used to control the temperature of a heat-treat oven and the Series 97 is being used as a safety limit with a retransmit output. Output 4 of the Series 97 must be equipped for retransmit (97__ - ___ M - ____).

The temperature of the limit process value is being recorded on a chart recorder. The oven temperature range stays between 600 to 900°F. The chart recorder requires a 4-20mA signal.

Set **Aout** Analog Output 4 (Output 4 Menu) to **Proc** Process 1 and **PrC4** Process 4 (Output 4 Menu) to **4-20** to tag the input 1 process value as the parameter to be retransmitted. Set Analog Output High **Ah_i** to 900 to set the high range for the retransmit signal. Set Analog Output Low **ALo** to 600 to set the low range for the retransmit signal. Set Analog Output Offset **ACAL** to 0, assuming no calibration offset is required.

The retransmit output will be 4mA until the oven temperature is greater than 600°F, at which point the signal will increase with temperature to 20mA at 900°F and will not exceed 20mA.

Alarms

An alarm takes some action, usually notifying an operator, when the process temperature leaves a defined range. A user can configure how and when an alarm is triggered and whether it turns off automatically when the alarm condition is over.

Alarm Set Points

The alarm high set point defines the temperature that will trigger a high side alarm. The alarm high set point must be higher than the alarm low set point and lower than the high limit of the sensor range.

The alarm low set point defines the temperature that will trigger a low side alarm. The alarm low set point must be lower than the alarm high set point and higher than the low limit of the sensor range.

Process alarm set points for output 2 can be viewed or changed with Alarm 2 High **R2h** and Alarm 2 Low **R2Lo** (Alarm Menu).

Alarm Hysteresis

Alarm hysteresis is a zone inside each alarm set point. This zone is defined by adding the hysteresis value to the alarm low set point or subtracting the hysteresis value from the alarm high set point.

An alarm state is triggered when the process value reaches the alarm high or alarm low set point. Alarm hysteresis defines how far the process must return into the normal operating range before the alarm can be cleared.

The alarm hysteresis value for output 2 can be viewed or changed with Hysteresis 2 **h452** (Output 2 Menu).

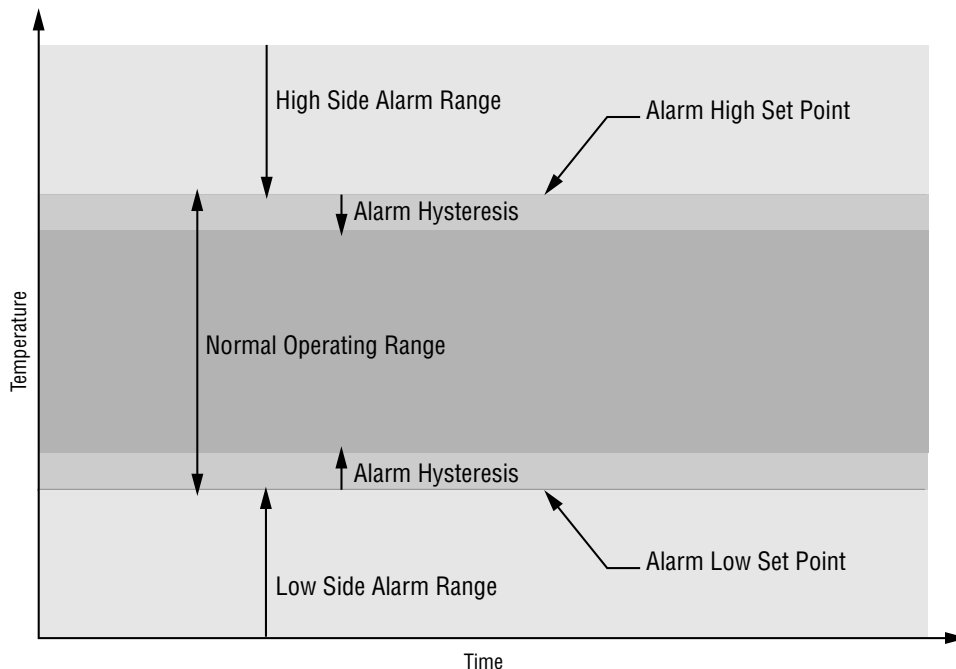

Figure 5.8 — Alarm settings.

Process

A process alarm uses one or two absolute set points to define an alarm condition.

The alarm process value of output 2 can be viewed or changed with Alarm 2 High **[A2H]** and Alarm 2 Low **[A2L]** (Alarm Menu).

Alarm Latching

A latched alarm will remain active after the alarm condition has passed. It can only be deactivated by the user. An alarm that is not latched will deactivate automatically when the alarm condition has passed.

Alarm 2 Latching **[AL2]** (Output 2 Menu) allows you to view or change whether the output 2 alarm will latch.

Clear a latched alarm by pressing the Reset key after the alarm condition has passed.

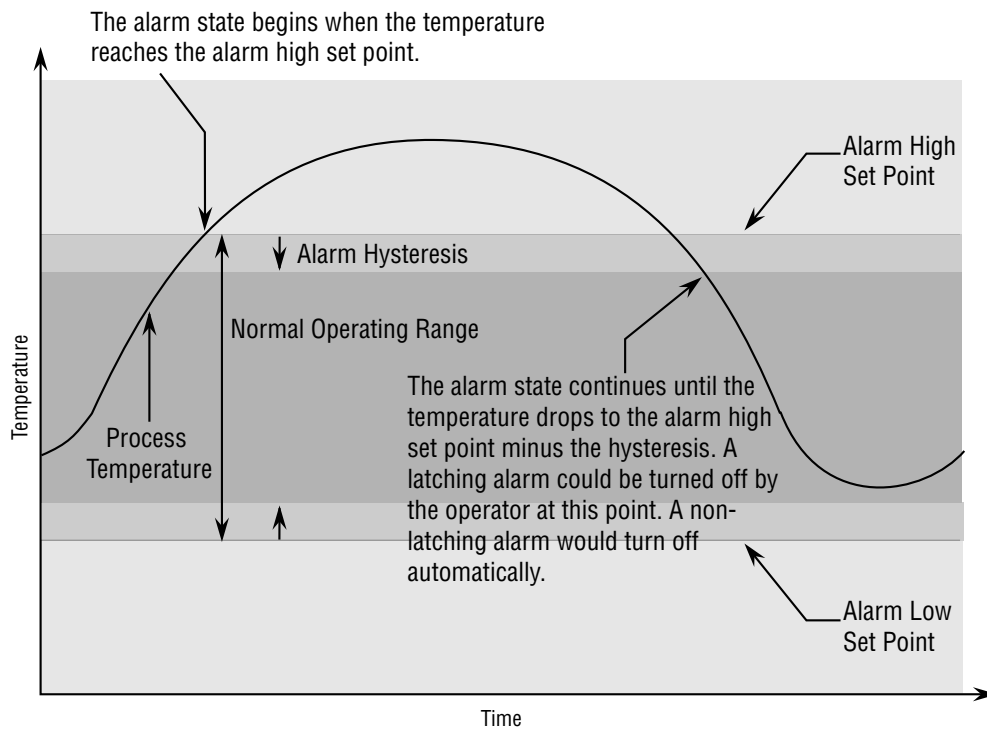

Figure 5.9 — Alarm latching.

Alarm Silencing

Alarm silencing has two uses:

1. It is often used to allow a system to warm up after it has been started up. With alarm silencing on, an alarm is not triggered when the process temperature is initially lower than the alarm low set point. The process temperature has to enter the normal operating range beyond the hysteresis zone in order to activate the alarm function.
2. Alarm silencing also allows the operator to disable the alarm output while the controller is in an alarm state. The process temperature has to enter the normal operating range beyond the hysteresis zone in order to activate the alarm output function.

Alarm Silencing 2 **SIL2** (Output 2 Menu) allows you to view or change whether alarm silencing is on. If Alarm Annunciation 2 **ANN2** (Output 2 Menu) is set to **YES**, the output 2 indicator light will remain on and an alarm message will appear in the display, even though the alarm is silenced.

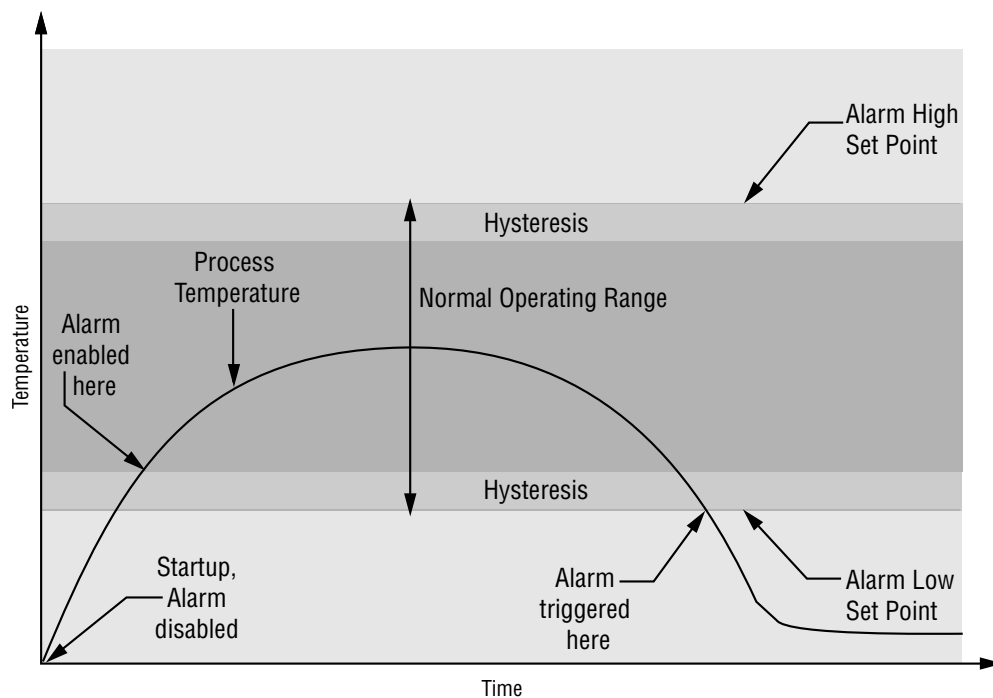

Figure 5.10 — Alarm silencing.

Communications

Overview

A Series 97 controller can also be programmed and monitored by connecting it to a personal computer or programmable logic controller (PLC) via serial communications. To use this communications option, a Series 97 must be equipped with an output 4 communications board for EIA/TIA-485 (97__ - ___U - ____), which allows as many as 32 controllers on a 4,000-foot-long network, or EIA/TIA-232 (97__ - ___R - ____), which allows a single controller to be connected to a computer.

The Series 97 uses an 8-N-1 data format (eight data bits, no parity, one stop bit and one start bit).

To view or change controller settings with a personal computer, you need to run software that uses the Modbus RTU protocol to read or write to registers in the controller. These registers contain the parameter values that determine how the controller will function and the values that reflect the current input and output values of the system. The parameters chapter lists the modbus address and range for each parameter. Refer to setup parameter table for setup order.

Communications parameters appear in the Output 4 Menu (Setup Page). Match the Baud Rate (**Baud**) to that of the computer and select an Address (**Addr**) for each Series 97.

The wiring chapter shows how to wire a Series 97 controller for EIA/TIA-485 or EIA/TIA-232 communications.

The Appendix provides technical information about programming for Modbus RTU.

NOTE: For more information about communicating with Watlow controllers, go to www.watlow.com and download the **Data Communications Reference: Electronic User's Manual**. It is located under Literature, User's Manuals, English and search on *data communications reference*.

Notes

6

Chapter Six Parameters

Parameter Setup Order	6.2
Home Page	6.3
Operations Page	6.4
Monitor Menu	6.4
Limit Menu	6.5
Alarm Menu	6.5
Setup Page	6.7
Input 1 Menu	6.7
Input 2 Menu	6.9
Output 1 Menu	6.9
Output 2 Menu	6.9
Output 3 Menu	6.11
Output 4 Menu	6.12
Display Menu	6.14
Global Menu	6.16
Factory Page	6.17
Lockout Menu	6.17
Diagnostics Menu	6.17
Input Calibration Menu	6.20
Output Calibration Menu	6.21

NOTE: To see how all the pages, menus and parameters are grouped, refer to the gatefold back cover of this manual.

For more information about how parameter settings affect the controller's operation, see Chapter Five, Features.

Table 6.2 — Set up parameters in this order.

Key:
D = Changing will change the **default**
C = Changing will **convert** the temperature scale
O = **Other** effect

	°C or °F [C-F]	Output 1 [Out1]	Output 2 [Out2]	Sensor Type [Sen1]	Input 1 [In1]	Range High 1 [rh1]	Range Low [rL1]	Decimal 1 [DEC1]	Input 2 [In2]
°C or °F [C-F]									
Output 1 [Out1]									
Output 2 [Out2]									
Output 3 [Out3]									
Output 4 [Out4]									
Sensor Type [Sen1]									
Input 1 [In1]				O					
Range High 1 [rh1]	C			D	D			C	
Range Low [rL1]	C			D	D			C	
Decimal 1 [DEC1]				D	D				
Calibration Offset 1 [CAL1]	C			D	D			C	
Input Software Filter 1 [Ftr1]				D	D			O	
Input 2 [In2]									
Event Function [Efn]									O
Event Condition [Ecn]									O
Analog Output 4 [Aout]				D	D				
Analog Output High [Ahi]	C			D	D			C	
Analog Output Low [Alo]	C			D	D			C	
Analog Output Offset [AOL]	C			D	D			C	
Alarm Hysteresis 2, 3, 4 [hYS2] [3] [4]	C			D	D			C	
Alarm Latching 2, 3, 4 [LAE2] [3] [4]									
Alarm Silencing 2, 3, 4 [SIL2] [3] [4]									
Alarm Active Sides 2, 3, 4 [Sid2] [3] [4]									
Alarm Logic 2, 3, 4 [Lgc2] [3] [4]									
Alarm 2, 3, 4 High [A2h] [3] [4]	C			D	D			C	
Alarm 2, 3, 4 Low [A2Lo] [3] [4]	C			D	D			C	

Changing this
Affects this

↓ →

Home Page

The resting-state display shows the following set of data. The first prompt appears in the top display, the second in the bottom.

Display	Parameter	Range	Default	Modbus Address read/write	Conditions for Parameters to Appear
<input type="checkbox"/> 97	Upper Display				Active: Always
<input checked="" type="checkbox"/> SRFE	Lower Display Monitor the processes determined by the Upper Display <input type="checkbox"/> UdSP and Lower Display <input type="checkbox"/> LdSP parameters Display Menu.				

NOTE: For more information about how parameter settings affect the controller's operation, see Chapter Five, Features.

Operations Page

The operations page contains three menus:

Display	Parameter	Range	Default	Modbus Address read/write	Conditions for Parameters to Appear
OPER	Operations Page Select Go to an operations menu.	non Monitor LI Limit AL Alarm (if any alarms are active)	LI		
non OPER	Monitor Menu Operations Page				
P1	Process 1 Monitor the process 1 value.			100 r	Active if Operations Page Mode (Lockout Menu) is not set to hide .
LS	Limit Status Monitor the condition of limit.	SAFE (0) hi (1) Lo (2)		319 r	Active if Operations Page Mode (Lockout Menu) is not set to hide .
AL 2	Alarm 2 Status Monitor alarm 2 status.	non (0) Lo (1) hi (2)		106 r	Active if Output 2 (Output 2 Menu) is set to AL and Operations Page Mode (Lockout Menu) is not set to hide .
AL 3	Alarm 3 Status Monitor alarm 3 status.	non (0) Lo (1) hi (2)		110 r	Active if Output 3 (Output 3 Menu) is set to AL and Operations Page Mode (Lockout Menu) is not set to hide .
AL 4	Alarm 4 Status Monitor alarm 4 status.	non (0) Lo (1) hi (2)		114 r	Active if Output 4 (Output 4 Menu) is set to AL and Operations Page Mode (Lockout Menu) is not set to hide .
ESI	Event Input Status Monitor the event input status.	FALSE false (0) true true (1)		201 r	Active if Input 2 (Input 2 Menu) is set to Ein (event input), EFn is not set to non and Operations Page Mode (Lockout Menu) is not set to hide .

NOTE: For more information about how parameter settings affect the controller's operation, see Chapter Five, Features.

Display	Parameter	Range	Default	Modbus Address read/write	Conditions for Parameters to Appear
Limit Menu OPER <i>Operations Page</i>					
L L o	Low Limit Set Point Sets the low limit point.	r L l to L h i -1	r L l	701 r/w	Active: Always
L h i	High Limit Set Point Sets the high limit point.	L L o +1 to r h i	r h i	702 r/w	Active: Always
CAL 1	Calibration Offset Sets the input 1 calibration offset.	-1999 to 9999	0	605 r/w	Active: Always
Alarm Menu OPER <i>Operations Page</i>					
A2Lo	Alarm 2 Low Sets the low alarm set point for output 2.	Process: low limit of selected sensor range to Alarm 2 High -1	Process: low limit of selected sensor range	321 r/w	Active if Output 2 (Output 2 Menu) is set to AL (Alarm), Alarm Active Sides 2 (Output 2 Menu) is not set to h i , Output 2 is present (97 ___ D ___ or 97 ___ K ___) and Operations Page Mode (Lockout Menu) is not set to h i d E .
A2h i	Alarm 2 High Sets the high alarm set point for output 2.	Process: Alarm 2 Low +1 to high limit of selected sensor range	Process: high limit of selected sensor range	322 r/w	Active if Output 2 (Output 2 Menu) is set to AL (Alarm), Alarm Active Sides 2 (Output 2 Menu) is not set to L o , Output 2 is present (97 ___ D ___ or 97 ___ K ___) and Operations Page Mode (Lockout Menu) is not set to h i d E .
A3Lo	Alarm 3 Low Sets the low alarm set point for output 3.	Process: low limit of selected sensor range to Alarm 3 High -1	Process: low limit of selected sensor range	340 r/w	Active if Output 3 (Output 3 Menu) is AL (Alarm), Alarm Sides 3 (Output 3 Menu) is not h i , or Output 3 is present (97 ___ D ___) and Operations Page Mode (Lockout Menu) is not set to h i d E .

NOTE: For more information about how parameter settings affect the controller's operation, see Chapter Five, Features.

Display	Parameter	Range	Default	Modbus Address read/write	Conditions for Parameters to Appear
R3h	Alarm 3 High Sets the high alarm set point for output 3.	Process: Alarm 3 Low +1 to high limit of selected sensor range	Process: high limit of selected sensor range	341 r/w	Active if Output 3 (Output 3 Menu) is AL (Alarm), Alarm Sides 3 (Output 3 Menu) is set to Lo , Output 3 is present (97 _ _ _ _ D _ _ _ _) and Operations Page Mode (Lockout Menu) is not set to h idE .
R4Lo	Alarm 4 Low Sets the low alarm set point for output 4.	Process: low limit of selected sensor range to Alarm 4 High -1	Process: low limit of selected sensor range	none*	Active if Output 4 (Output Menu 4) is AL (Alarm), Alarm Sides 4 (Output Menu 4) is not h , Output 4 is a relay (97 _ _ _ _ D _ _ _ _) and Operations Page Mode (Lockout Menu) is not set to h idE .
R4h	Alarm 4 High Sets the high alarm set point for output 4.	Process: Alarm 4 Low +1 to high limit of selected sensor range	Process: high limit of selected sensor range	none*	Active if Output 4 (Output Menu 4) is AL (Alarm), Alarm Sides 4 (Output Menu 4) is not set to Lo , Output 4 is a relay (97 _ _ _ _ D _ _ _ _) and Operations Page Mode (Lockout Menu) is not set to h idE .

*Output 4 parameters cannot be changed with the Modbus interface.

NOTE: For more information about how parameter settings affect the controller's operation, see Chapter Five, Features.

Setup Page

The setup page contains 8 menus.

Display	Parameter	Range	Default	Modbus Address read/write	Conditions for Parameters to Appear
<input type="checkbox"/> SEt	Setup Page Go to a setup menu.	<input type="checkbox"/> INP1 Input 1 <input type="checkbox"/> INP2 Input 2 (if present) <input type="checkbox"/> OUT1 Output 1 <input type="checkbox"/> OUT2 Output 2 (if present) <input type="checkbox"/> OUT3 Output 3 (if present) <input type="checkbox"/> OUT4 Output 4 (if present) <input type="checkbox"/> dISP Display <input type="checkbox"/> GLbL Global	<input type="checkbox"/> INP1		Active if Setup Page Lock (Lockout Menu) is not set to <input type="checkbox"/> hIdE .
<input type="checkbox"/> INP1	Input 1 Menu				
<input type="checkbox"/> SEt	Setup Page				
<input type="checkbox"/> SEn1	Sensor Type 1 Sets the input hardware type of input 1.	<input type="checkbox"/> tc Thermocouple (0) <input type="checkbox"/> rtD RTD (1)	<input type="checkbox"/> tc	600 r/w	Active if Setup Page Lock (Lockout Menu) is not set to <input type="checkbox"/> hIdE .
<input type="checkbox"/> IN1	Input 1 Sets the input linearization parameter of the input 1.	If Sensor Type is set to thermocouple <input type="checkbox"/> J J (0) <input type="checkbox"/> H K (1) <input type="checkbox"/> T T (2) <input type="checkbox"/> E E (3) <input type="checkbox"/> N N (4) <input type="checkbox"/> C C (5) <input type="checkbox"/> D D (6) <input type="checkbox"/> PT2 PT2 (7) <input type="checkbox"/> R R (8) <input type="checkbox"/> S S (9) <input type="checkbox"/> B B (10) if Sensor Type is set to RTD <input type="checkbox"/> dIN RTD_DIN (11) <input type="checkbox"/> JIS RTD_JIS (12)	If Sensor Type (Input 1 Menu) is changed to thermocouple: <input type="checkbox"/> J , if Sensor Type is changed to RTD: <input type="checkbox"/> dIN	601 r/w	Active if Setup Page Lock (Lockout Menu) is not set to <input type="checkbox"/> hIdE .

NOTE: For more information about how parameter settings affect the controller's operation, see Chapter Five, Features.

Display	Parameter	Range	Default	Modbus Address read/write	Conditions for Parameters to Appear
rl	Range Low 1 Sets the input range low. This setting is the lowest value that the set point can have.	*	*	602 r/w	Active if Setup Page Lock (Lockout Menu) is not set to hide .
rh	Range High 1 Sets the input range high. This setting is the highest value that the set point can have.	*	*	603 r/w	Active if Setup Page Lock (Lockout Menu) is not set to hide .
dec	Decimal 1 Sets the position of the decimal point for input readings.	If Set Sensor Type is RTD, thermocouple, (excluding R, S, or B thermocouple) 0 0(0) 0.0 0.0(1)	0	606 r/w	Active if Setup Page Lock (Lockout Menu) is not set to hide .
fer	Input Software Filter 1 Sets the filter time for the input, in seconds. This smooths out a rapidly changing input signal. Positive values affect the monitor readings only. Negative values affect both the monitor readings and the control values.	-60.0 to 60.0	0 (or 1.0 if dec is set to 0.0)	604 r/w	Active if Setup Page Lock (Lockout Menu) is not set to hide .

*See specifications in the appendix for sensor ranges and defaults.

NOTE: For more information about how parameter settings affect the controller's operation, see Chapter Five, Features.

Display	Parameter	Range	Default	Modbus Address read/write	Conditions for Parameters to Appear
INP2 SET	Input 2 Menu Setup Page				
IN 2	Input 2 Sets the input type parameter of input 2.	OFF off: (0) Ein Event Input: (1)	0	611 r/w	Active if Input 2 hardware is present (97_1_ _ _ _ _ _ _ _ _ _) and Setup Page Lock (Lockout Menu) is not set to hide .
EFn	Event Function Selects the event function.	nonE no function (0) LrSE reset limit (1) LOC lock out key board (2) ALr clear and silence alarms if possible (3)	nonE	1060 r/w	Active if Input 2 hardware is present (97_1_ _ _ _ _ _ _ _ _ _) or Input 2 (Input 2 Menu) is set to Ein (Event Input) and Setup Page Lock (Lockout Menu) is not set to hide .
ECn	Event Condition Selects the condition to trigger an event.	Lo low (0) h, high (1) r,SE rise (2) FALL fall (3)	Lo	1061 r/w	Active if Input 2 hardware is present (97_1_ _ _ _ _ _ _ _ _ _), Input 2 (Input 2 Menu) is set to Ein (Event Input), Event Function (Input 2 Menu) is not set to nonE and Setup Page Lock (Lockout Menu) is not set to hide .
OUT1 SET	Output 1 Menu Setup Page				
LSid	Limit Active Sides Selects output 1 active sides.	both both (0) h, high (1) Lo low (2)	both	700 r/w	Active: Always.
LhYS	Limit Hysteresis Sets the switching hysteresis for output 1.	1 to 9999	3	507 r/w	Active: Always.
OUT2 SET	Output 2 Menu Setup Page				
OE 2	Output 2 Selects output 2 function.	OFF off (0) AL alarm (1)	OFF	717 r/w	Active if Output 2 hardware is present (not 97_ _ _ A _ _ _ _ _) and Setup Page Lock (Lockout Menu) is not set to hide .

NOTE: For more information about how parameter settings affect the controller's operation, see Chapter Five, Features.

Display	Parameter	Range	Default	Modbus Address read/write	Conditions for Parameters to Appear
hY52	Alarm Hysteresis 2 Sets the switching hysteresis for the alarm output. This defines a band on the inside of the alarm set point. When the process temperature is in this band, the alarm state will not change.	1 to 9999	3	720 r/w	Active if Output 2 is enabled, hardware is present (not 97 _ _ _ A _ _ _ _ _), Output 2 (Output 2 Menu) is set to <input type="checkbox"/> AL (Alarm) and Setup Page Lock (Lockout Menu) is not set to <input type="checkbox"/> h i d E .
LRt2	Latching 2 Enables Alarm 2 Latching.	<input type="checkbox"/> no no action (0) <input type="checkbox"/> YES latching enabled (1)	<input type="checkbox"/> no	721 r/w	Active if Output 2 (Output 2 Menu) is set to <input type="checkbox"/> AL (Alarm) and Setup Page Lock (Lockout Menu) is not set to <input type="checkbox"/> h i d E .
S.L2	Silencing 2 Enables Silence 2.	<input type="checkbox"/> no no action (0) <input type="checkbox"/> YES silence alarm (1)	<input type="checkbox"/> no	722 r/w	Active if Output 2 (Output 2 Menu) is set to <input type="checkbox"/> AL (Alarm) and Setup Page Lock (Lockout Menu) is not set to <input type="checkbox"/> h i d E .
S.i2	Alarm Active Sides 2 Selects which side or sides the alarm setpoints can be programmed for.	<input type="checkbox"/> both both (0) <input type="checkbox"/> h i high (1): high side only <input type="checkbox"/> Lo low (2): low side only	<input type="checkbox"/> both	723 r/w	Active if Output 2 (Output 2 Menu) is set to <input type="checkbox"/> AL , hardware is present (not 97 _ _ _ A _ _ _ _ _), and Setup Page Lock (Lockout Menu) is not set to <input type="checkbox"/> h i d E .
LRc2	Alarm Logic 2 Selects alarm 2 output condition in the alarm state.	<input type="checkbox"/> AL 0 alarm condition de-energizes output (fail safe operation) (0) <input type="checkbox"/> AL 1 alarm condition energizes output (1)	<input type="checkbox"/> AL 0	724 r/w	Active if Output 2 (Output 2 Menu) is set to <input type="checkbox"/> AL , hardware is present (not 97 _ _ _ A _ _ _ _ _), and Setup Page Lock (Lockout Menu) is not set to <input type="checkbox"/> h i d E .
Ann2	Alarm Annunciation 2 Selects alarm 2 annunciation option.	<input type="checkbox"/> no no (0) <input type="checkbox"/> YES yes (1)	<input type="checkbox"/> YES	725 r/w	Active if Output 2 is set to <input type="checkbox"/> AL , hardware is present (not 97 _ _ _ A _ _ _ _ _), and Setup Page Lock (Lockout Menu) is not set to <input type="checkbox"/> h i d E .

NOTE: For more information about how parameter settings affect the controller's operation, see Chapter Five, Features.

Display	Parameter	Range	Default	Modbus Address read/write	Conditions for Parameters to Appear
OUT3 SET	Output 3 Menu Setup Page				
OUT3	Output 3 Selects type of output 3.	OFF off (0) AL alarm (1)	OFF	734 r/w	Active if Output 3 hardware is present (97 _ _ _ _ D _ _ _ _ _), Output 3 (Output 3 Menu) is set to AL (Alarm) and Setup Page Lock (Lockout Menu) is not set to hide .
HYS3	Alarm Hysteresis 3 Sets the switching hysteresis for the alarm output. This defines a band on the inside of the alarm set point. When the process temperature is in this band, the alarm state will not change.	1 to 9999	3	737 r/w	Active if Output 3 hardware is present (97 _ _ _ _ D _ _ _ _ _), Output 3 (Output 3 Menu) is set to AL (Alarm) and Setup Page Lock (Lockout Menu) is not set to hide .
LATCH3	Latching 3 Enables Alarm 3 Latching.	no no action (0) YES latching enabled (1)	no	738 r/w	Active if Output 3 hardware is present (97 _ _ _ _ D _ _ _ _ _), Output 3 (Output 3 Menu) is set to AL (Alarm) and Setup Page Lock (Lockout Menu) is not set to hide .
SILE3	Silencing 3 Enables Silence 3.	no no action (0) YES silence 3 enabled (1)	no	739 r/w	Active if Output 3 hardware is present (97 _ _ _ _ D _ _ _ _ _), Output 3 (Output 3 Menu) is set to AL (Alarm) and Setup Page Lock (Lockout Menu) is not set to hide .
SIDE3	Alarm Active Sides 3 Selects alarm 3 side option.	both both (0) hi high (1) lo low (2)	both	740 r/w	Active if Output 3 hardware is present (97 _ _ _ _ D _ _ _ _ _), Output 3 (Output 3 Menu) is set to AL (Alarm) and Setup Page Lock (Lockout Menu) is not set to hide .
LOG3	Alarm Logic 3 Selects alarm 3 output condition in the alarm state.	AL D alarm condition de-energizes output (fail safe operation) (0) AL C alarm condition energizes output (1)	AL D	741 r/w	Active if Output 3 hardware is present (97 _ _ _ _ D _ _ _ _ _), Output 3 (Output 3 Menu) is set to AL (Alarm) and Setup Page Lock (Lockout Menu) is not set to hide .

NOTE: For more information about how parameter settings affect the controller's operation, see Chapter Five, Features.

Display	Parameter	Range	Default	Modbus Address read/write	Conditions for Parameters to Appear
Ann3	Alarm Annunciation 3 Selects alarm 3 annunciation option.	<input type="checkbox"/> no no (0) <input checked="" type="checkbox"/> yes yes (1)	<input checked="" type="checkbox"/> yes	742 r/w	Active if Output 3 hardware is present (97 _ _ _ _ D _ _ _ _), Output 3 (Output 3 Menu) is set to <input type="checkbox"/> AL (Alarm) and Setup Page Lock (Lockout Menu) is not set to <input type="checkbox"/> hide .
<hr/>					
Out4 Set	Output 4 Menu Setup Page				
OE 4	Output 4 Selects output 4 type.	<input type="checkbox"/> OFF off <input checked="" type="checkbox"/> AL alarm	<input type="checkbox"/> OFF	none*	Active if Output 4 is equipped for a relay (97 _ _ _ _ D _ _ _ _) and Setup Page Lock (Lockout Menu) is not set to <input type="checkbox"/> hide .
hYS4	Alarm Hysteresis 4 Sets the switching hysteresis for the alarm output. This defines a band on the inside of the alarm set point. When the process temperature is in this band, the alarm state will not change.	1 to 9999	3	none*	Active if Output 4 is equipped for a relay, (97 _ _ _ _ D _ _ _ _), Output 4 (Output 4 Menu) is set to <input type="checkbox"/> AL (Alarm) and Setup Page Lock (Lockout Menu) is not set to <input type="checkbox"/> hide .
LRE4	Latching 4 Enables alarm 4 latching.	<input type="checkbox"/> no no action <input checked="" type="checkbox"/> yes latching enabled	<input type="checkbox"/> no	none*	Active if Output 4 is equipped for a relay (97 _ _ _ _ D _ _ _ _), Output 4 (Output 4 Menu) is set to <input type="checkbox"/> AL (Alarm) and Setup Page Lock (Lockout Menu) is not set to <input type="checkbox"/> hide .
SIL4	Silencing 4 Enables Silence 4.	<input type="checkbox"/> no no action <input checked="" type="checkbox"/> yes silence 4 enabled	<input type="checkbox"/> no	none*	Active if Output 4 is equipped for a relay (97 _ _ _ _ D _ _ _ _), Output 4 (Output 4 Menu) is set to <input type="checkbox"/> AL (Alarm) and Setup Page Lock (Lockout Menu) is not set to <input type="checkbox"/> hide .
Sid4	Alarm Active Sides 4 Selects alarm 4 side option.	<input checked="" type="checkbox"/> both both <input type="checkbox"/> hi high <input type="checkbox"/> Lo low	<input checked="" type="checkbox"/> both	none*	Active if Output 4 is equipped for a relay (97 _ _ _ _ D _ _ _ _), Output 4 (Output 4 Menu) is set to <input type="checkbox"/> AL (Alarm) and Setup Page Lock (Lockout Menu) is not set to <input type="checkbox"/> hide .

*Output 4 parameters cannot be changed with the Modbus interface.

NOTE: For more information about how parameter settings affect the controller's operation, see Chapter Five, Features.

Display	Parameter	Range	Default	Modbus Address read/write	Conditions for Parameters to Appear
L9c4	Alarm Logic 4 Selects alarm 4 output condition in alarm state.	AL 0 alarm condition de-energizes output AL C alarm condition energizes output	AL 0	none*	Active if Output 4 is equipped for a relay (97 _ _ _ _ D- _ _ _ _), Output 4 (Output 4 Menu) is set to AL (Alarm) and Setup Page Lock (Lockout Menu) is not set to h i d E .
Rnu4	Alarm Annunciation 4 Selects alarm 4 annunciation option.	no no YES yes	YES	none*	Active if Output 4 is equipped for a relay (97 _ _ _ _ D- _ _ _ _), Output 4 is Set to AL (Alarm) and Setup Page Lock (Lockout Menu) is not set to h i d E .
Rout	Analog Output 4 Selects output 4 retransmit signal.	no not active Proc process	Proc	none*	Active if Output 4 is equipped for retransmit (97 _ _ _ _ M- _ _ _ _) and Setup Page Lock (Lockout Menu) is not set to h i d E .
PrC4	Process 4 Type Sets process 4 output type.	4-20 4-20 mA 0-20 0-20 mA 0-5 0-5V ^{dc} 1-5 1-5V ^{dc} 0-10 0-10V ^{dc}	4-20	none*	Active if Output 4 is equipped for retransmit (97 _ _ _ _ M- _ _ _ _) and Setup Page Lock (Lockout Menu) is not set to h i d E .
ALo	Analog Output Low Sets analog output range low scaling.	-1999 to Analog Range High	-999	none*	Active if Output 4 is equipped for retransmit (97 _ _ _ _ M- _ _ _ _), and Analog Output 4 (Output 4 Menu) is set to Proc and Setup Page Lock (Lockout Menu) is not set to h i d E .
AHi	Analog Output High Sets analog output range high scaling.	Analog Range Low to 9999	999	none*	Active if Output 4 is equipped for retransmit (97 _ _ _ _ M- _ _ _ _), and Analog Output 4 (Output 4 Menu) is set to YES and Setup Page Lock (Lockout Menu) is not set to h i d E .
RCAL	Analog Output Offset Sets analog output offset.	-1999 to 9999	0	none*	Active if Output 4 is retransmit (97 _ _ _ _ M- _ _ _ _), and Analog Output 4 (Output 4 Menu) is set to YES and Setup Page Lock (Lockout Menu) is not set to h i d E .
BRUd	Baud Rate Sets communications baud rate.	1200 1200 2400 2400 4800 4800 9600 9600 19.2K 19.2K	9600	none*	Active if Output 4 is equipped for communications (97 _ _ _ _ R- _ _ _ _ or 97 _ _ _ _ U- _ _ _ _) and Setup Page Lock (Lockout Menu) is not set to h i d E .

*Output 4 parameters cannot be changed with the Modbus interface.

NOTE: For more information about how parameter settings affect the controller's operation, see Chapter Five, Features.

Display	Parameter	Range	Default	Modbus Address read/write	Conditions for Parameters to Appear
	Addr Address Sets communications address.	1 to 247	1	none*	Active if Output 4 is equipped for communications (97 _ _ _ _ R- _ _ _ _ or 97 _ _ _ _ U- _ _ _ _) and Setup Page Lock (Lockout Menu) is not set to hidE .
	dISP Display Menu SEt Setup Page				
	UDSP Upper Display Selects the value that will appear in the upper display. Alarm messages will toggle in the upper display if out of alarm range.	PrI actual temperature (0) USEr user message (1) LhI high limit set point (3) LLo low limit set point (2)	PrI	1400 r/w	Active: Always.

*Output 4 parameters cannot be changed with the Modbus interface.

NOTE: For more information about how parameter settings affect the controller's operation, see Chapter Five, Features.

Display	Parameter	Range	Default	Modbus Address read/write	Conditions for Parameters to Appear
UP L	Upper Display User Limit Message Select four characters for limit message.	0: _ 1: A 2: b 3: C 4: c 5: d 6: E 7: e 8: F 9: g 10: H 11: h 12: I 13: i 14: J 15: L 16: l 17: M (1st half) 18: M (2nd half) 19: N 20: n 21: O 22: o 23: P 24: r 25: S 26: t 27: U 28: u 29: W (1st half) 30: W (2nd half) 31: backwards "C" 32: backwards "c" 33: y 34: 0 35: 1 36: 2 37: 3 38: 4 39: 5 40: 6 41: 7 42: 8 43: 9 44: blank 45: - 46: . 47: -1 48: li 49: il 50: ll 51: i 52: l 53: l 54: °		1401 r/w 1402 r/w 1403 r/w 1404 r/w characters 1 to 4	Active if Upper Display UDSP is set to USER .

NOTE: For more information about how parameter settings affect the controller's operation, see Chapter Five, Features.

Display	Parameter	Range	Default	Modbus Address read/write	Conditions for Parameters to Appear
LdSP	Lower Display Selects the value or message that will appear in the lower display. Limit Status or User Limit Message, if selected, will flash in the lower display if out of limit range.	LSE limit status (0): SAFE ; hi ; Lo USER user message (1) Lhi high limit set point (3) LLo low limit set point (2)	LSE	1405 r/w	Active: Always.
LoS	Lower Display User Safe Message Selects four characters for user message to appear while the unit is in a safe condition.	see Upper Display User Limit Message	-----	1406 r/w 1407 r/w 1408 r/w 1409 r/w characters 1 to 4	Active if Lower Display LdSP is set to USER .
LoL	Lower Display User Limit Message Selects four characters for the user message to appear while the unit is in a limit condition.	see Upper Display User Limit Message	-----	1410 r/w 1411 r/w 1412 r/w 1413 r/w characters 1 to 4	Active if Lower Display LdSP is set to USER .
GLbL SEt	Global Menu Setup Page				
C-F	C or F Selects the temperature scale for the input. Converts all temperature parameters.	oC Celsius (1) oF Fahrenheit (0)	oF	901 r/w	Active if Setup Page Lock (Lockout Menu) is not set to hide .
Err	Input Error Latching Selects input error latching mode.	LRE latching (0) nLRE no latching (1)	nLRE	607 r/w	Active if Setup Page Lock (Lockout Menu) is not set to hide .

NOTE: For more information about how parameter settings affect the controller's operation, see Chapter Five, Features.

Factory Page

The factory page contains four menus:

Display	Parameter	Range	Default	Modbus Address read/write	Conditions for Parameters to Appear
FcEY	Factory Page Selection Choose factory menu to enter.	LOC Lockout Menu d1R9 Diagnostics Menu cin1 Calibration 1 Menu couE Process Output Calibration Menu	cin1		Active: Always
LOC FcEY	Lockout Menu Factory Page				
OPER	Operations Page Mode Lock Sets the Operations Page lockout level.	hide hide (0) chn9 change (1) rERd read (2)	chn9	1301 r/w	Active: Always
SEt	Setup Page Lock Sets the Setup Page lockout level.	hide hide (0) chn9 change (1) rERd read (2)	chn9	1302 r/w	Active: Always
CAL	Calibration Menu Lock Sets the calibration menu lockout level.	hide hide (0) chn9 change (1) rERd read (2)	chn9	1305 r/w	Active: Always
d1R9 FcEY	Diagnostics Menu Factory Page				
m7dL	Model Number Reads the model number of the controller.	97	97	0 r	Active: Always
dRtE	Date of Manufacture Displays date as WEEK:YEAR (WWYY).	0197 to 9999	0197	5 r	Active: Always

NOTE: For more information about how parameter settings affect the controller's operation, see Chapter Five, Features.

Display	Parameter	Range	Default	Modbus Address read/write	Conditions for Parameters to Appear
5n1	Serial Number 1 Reads the first four digits of the serial number.	0 to 9999	none	1 r	Active: Always
5n2	Serial Number 2 Reads the last four digits of the serial number.	0 to 9999	none	2 r	Active: Always
5oFt	Software ID Number Reads the software ID number.	0 to 9999	none	3 r	Active: Always
rEu	Software Revision Reads software revision number.	0.00 to 99.99	none	4 r	Active: Always
1E92	Input 2 Hardware Enabled Enables the input 2 hardware.	none (0) PrEE Process Event (5)	none	9 r	Active: Always
0E91	Output 1 Hardware Reads the output 1 hardware type.	rELY relay (1)	rELY	16 r	Active: Always
0E92	Output 2 Hardware Reads the output 2 hardware type.	nonE none (0) rELY relay (1) SSr solid-state relay (2) dc dc (3)	nonE	17 r	Active: Always
0E93	Output 3 Hardware Reads the output 3 hardware type.	nonE none (0) rELY relay (1)	nonE	18 r	Active: Always
0E94	Output 4 Hardware Reads the output 4 hardware type.	nonE none (0) rELY relay (1) Prac process (4) 485 (6) 232 (7)	nonE	19 r	Active: Always

NOTE: For more information about how parameter settings affect the controller's operation, see Chapter Five, Features.

Display	Parameter	Range	Default	Modbus Address read/write	Conditions for Parameters to Appear
OUT	Test Output Turns on specific output.	none none (0) OUT1 Output 1 (1) OUT2 Output 2 (2) OUT3 Output 3 (3) OUT4 Output 4 (4) ALL all outputs (5)	none	1514 r/w	Active: Always
DISP	Test Display Tests the indicator lights on the front panel.	OFF turn off cyclical display test (0) on turn on the cyclic display test (1)	OFF	1513 r/w	Active: Always
HRRES	High Resolution Displays high resolution input value.	0.0 to 99.9	none	1707 r	Active: Always
TEMP	Ambient Temperature Reads the ambient temperature in 0.1 degrees Fahrenheit.		none	1500 r	Active: Always
RCNT	Ambient A-D Counts Displays the raw ambient channel A-D counts.		none	1501 r	Active: Always
CNT1	Channel 1 A-D Counts Displays the raw channel 1 A-D counts.		none	1504 r	Active: Always
CNT2	Channel 2 A-D Counts Displays the raw channel 2 A-D counts.		none	1505 r	Active: Always
ESHT	Communication Test and Troubleshooting Helps solve problems with the controller.	no (0) CONF sends Modbus packet every one second (2)	none		
LINE	Line Frequency Displays the AC line frequency in Hz.		none	1515 r	Active: Always

NOTE: For more information about how parameter settings affect the controller's operation, see Chapter Five, Features.

Display	Parameter	Range	Default	Modbus Address read/write	Conditions for Parameters to Appear
cin1	Input Calibration Menu				
Fcty	Factory Page				
r5t	Restore Factory Calibration Restores factory calibration (Stores factory calibration with special key sequence).	<input type="checkbox"/> no No (0) <input type="checkbox"/> yes Yes (1)	<input type="checkbox"/> no	1601 w	Active if Calibration Lock (Lockout Menu) is not set to hide
dflt	Default Settings Restores default settings.	<input type="checkbox"/> no no (0) <input type="checkbox"/> yes yes (800)	<input type="checkbox"/> no	1602 w	Active if Calibration Lock (Lockout Menu) is not set to hide
tc50	Thermocouple Calibration, 50mV Stores 50.000mV calibration for input 1 thermocouple.	<input type="checkbox"/> no no (0) <input type="checkbox"/> yes yes (2)	<input type="checkbox"/> no	1603 w	Active if Calibration Lock (Lockout Menu) is not set to hide
tc00	Thermocouple Calibration, 0mV Stores 0.000mV calibration for input 1 thermocouple.	<input type="checkbox"/> no no (0) <input type="checkbox"/> yes yes (1)	<input type="checkbox"/> no	1603 w	Active if Calibration Lock (Lockout Menu) is not set to hide
tc32	Thermocouple Calibration, 32° Stores 32 degrees F type J calibration.	<input type="checkbox"/> no no (0) <input type="checkbox"/> yes yes (3)	<input type="checkbox"/> no	1603 w	Active if Calibration Lock (Lockout Menu) is not set to hide
gnd	Set Ground Stores calibration for ground at gains of 1 and 32.	<input type="checkbox"/> no no (0) <input type="checkbox"/> yes yes (4)	<input type="checkbox"/> no	1603 w	Active if Calibration Lock (Lockout Menu) is not set to hide
LEAd	Lead Resistance Calibration Stores calibration for lead resistance.	<input type="checkbox"/> no no (0) <input type="checkbox"/> yes yes (5)	<input type="checkbox"/> no	1603 w	Active if Calibration Lock (Lockout Menu) is not set to hide
r15	RTD Calibration, 15Ω Stores 15.00Ω calibration for input 1 RTD.	<input type="checkbox"/> no no (0) <input type="checkbox"/> yes yes (6)	<input type="checkbox"/> no	1603 w	Active if Calibration Lock (Lockout Menu) is not set to hide
r380	RTD Calibration, 380Ω Stores 380.00Ω calibration for input 1 RTD.	<input type="checkbox"/> no no (0) <input type="checkbox"/> yes yes (7)	<input type="checkbox"/> no	1603 w	Active if Calibration Lock (Lockout Menu) is not set to hide

NOTE: For more information about how parameter settings affect the controller's operation, see Chapter Five, Features.

Display	Parameter	Range	Default	Modbus Address read/write	Conditions for Parameters to Appear
COUL	Output Calibration Menu				
FCT4	Factory Page				
4 4	Output Calibration 4, 4mA Enter the output value in milliamps as measured.	0.00 to 99.99	4.00	1619 w	Active if Output 4 is process (97 _ _ _ _ M _ _ _ _) and Calibration Lock (Lockout Menu) is not set to h i d E
4 20	Output Calibration 4, 20mA Enter the output value in milliamps as measured.	0.00 to 99.99	20.00	1620 w	Active if Output 4 is process (97 _ _ _ _ M _ _ _ _) and Calibration Lock (Lockout Menu) is not set to h i d E
4 1	Output Calibration 4, 1V Enter the output value in volts as measured.	0.00 to 99.99	1.00	1621 w	Active if Output 4 is process (97 _ _ _ _ M _ _ _ _) and Calibration Lock (Lockout Menu) is not set to h i d E
4 10	Output Calibration 4, 10V Enter the output value in volts as measured.	0.00 to 99.99	10.00	1622 w	Active if Output 4 is process (97 _ _ _ _ M _ _ _ _) and Calibration Lock (Lockout Menu) is not set to h i d E

NOTE: For more information about how parameter settings affect the controller's operation, see Chapter Five, Features.

Notes

NOTE: For more information about how parameter settings affect the controller's operation, see Chapter Five, Features.

A

Appendix



Troubleshooting Alarms and Errors	A.2
Modbus™ RTU	A.4
Modbus Address Chart	A.10
Calibrating the Series 97	A.11
Glossary	A.14
Specifications	A.18
Ordering Information	A.20
Index	A.21
Prompt Index	A.23
Declaration of Conformity	A.24
Software Map	inside back cover
Warranty Information	back cover

Troubleshooting Alarms and Errors

Indication	Probable Cause(s)
Power	
<ul style="list-style-type: none"> No power. 	<ul style="list-style-type: none"> Power to unit may be off. Fuse may be blown. Breaker may be tripped. Safety interlock door switch etc. may be activated. Wiring may be open. Input Power may not be hooked up to pins 8 and 9.
Communications	
<ul style="list-style-type: none"> Unit will not communicate. 	<ul style="list-style-type: none"> Address parameter may be incorrectly set. Baud rate parameter may be incorrectly set. Unit-to-unit daisy chain may be disconnected. Communications wiring may be reversed, short or open. EIA-485 converter box may be incorrectly wired. Computer COM port may be incorrectly set up. Communications software setup or address may be incorrect. Protocol or parity may be wrong, should be 8, n, 1. Application software not working properly. May need termination and pull-up and pull-down resistors.
Input Error (error number in top display, percent power in bottom)	
<ul style="list-style-type: none"> Input is in error condition. 	<ul style="list-style-type: none"> The sensor may be improperly wired. Sensor wiring may be reversed, shorted or open. Input type setting may be for the wrong sensor / may not be calibrated. Power may be incorrect. Ambient temperature may be too hot or too cold. The open loop detect shows a broken sensor. The calibration offset parameter is set much too high or low.
<code>Err 1</code> Underflow	
<code>Err 2</code> Under Sensor Range	
<code>Err 3</code> Over Sensor Range	
<code>Err 4</code> Overflow	
Alarms	
<ul style="list-style-type: none"> Alarm won't occur. 	<ul style="list-style-type: none"> Alarm output may be off. Alarm set points may be incorrect. Alarm may be silenced. Alarm sides may be incorrect. Controller may be in diagnostics mode.
<ul style="list-style-type: none"> Alarm won't clear. 	<ul style="list-style-type: none"> Alarm may be latched. Alarm set points may be incorrect. Alarm hysteresis may be incorrect. Input may be in error condition.
Unit Errors (error number in top display, error message in bottom display)	
<ul style="list-style-type: none"> <code>Er 4</code> <code>RAM</code> <code>Er 5</code> <code>EEPROM</code> <code>Er 6</code> <code>PROM</code> <code>Er 7</code> <code>Hard</code> <code>Er 8</code> <code>PLU9</code> <code>Er 9</code> <code>cnF9</code> <code>Er 10</code> <code>chn9</code> <code>Er 11</code> <code>Soft</code> <code>Er 12</code> <code>cRL</code> <code>Er 13</code> <code>Atod</code> <code>Er 14</code> <code>EEPROM</code> <code>Er 15</code> <code>nELU</code> <code>Er 16</code> <code>Addr</code> 	<ul style="list-style-type: none"> There is a RAM malfunction. The EEPROM data is corrupted. There is a PROM malfunction. There is a logic hardware problem. Module error. Configuration error. Module in invalid position. Module changed. New firmware is installed. Calibration data is corrupted. There is an analog-to-digital hardware failure. There is an EEPROM hardware problem. It is the new unit's first power up. There is an EEPROM hardware problem.

Corrective Action

- Check switches, fuses, breakers, interlocks, limits, connectors, etc. for energized condition and proper connection.

- Measure power upstream for required level. Check part number for input power required.
- Check wire size.
- Check for bad or incorrect connections.

- Check comms setup menu and set to correct address.
- Check comms setup menu and set to correct baud rate.
- Look for a break in the daisy chain.
- Verify correct connections and test wiring paths.
- Check converter box wiring and its documentation.
- Reconfigure computer's COM port setup and verify communications ok.
- Check the communication card documentation for settable variables and operational testing.
- Restart COMS software and check for settings agreement. Verify the COM bus is active.
- Verify operation with Watlow comms tool.

- Check sensor connections.
- Check sensor connections and sensor wiring.
- Change the Sensor Type parameter to match the sensor hardware.
- Measure power upstream for required level. Check part number for power requirements.
- Verify that the temperature surrounding the controller is 32 to 149°F (0 to 65°C).
- Check sensor function. The Open Loop Detect parameter indicates it may be broken.
- Check the Calibration Offset parameter value; set it to a lower level.

- Configure output as an alarm.
- Check alarm set points.
- To clear the alarm, correct the alarm condition; check to see if the alarm is latched.
- Check the alarm sides setting.
- Check the alarm type setting.
- Check the alarm logic for compatibility with system peripherals and annunciators.
- Check the power limit setting.
- Check the operation mode.
- Check the alarm output function.
- Check the °C or °F setting.
- Check the calibration offset value; set it to a lower level.

- Cycle power to unit. If problem persists, return unit to factory.
- Cycle power to unit.
- Cycle power to unit. If problem persists, return unit to factory.
- Cycle power to unit. If problem persists, return unit to factory.
- Module defective, replace or verify module configuration.
- Return unit to factory.
- Cycle power to unit.
- Cycle power to unit.
- Recalibrate unit.
- Cycle power to unit. If problem persists, return unit to factory.
- Cycle power to unit. If problem persists, return unit to factory.
- Cycle power to unit. If problem persists, return unit to factory.
- Cycle power to unit. If problem persists, return unit to factory.

Modbus Remote Terminal Unit (RTU)

Modbus RTU enables a computer or PLC to read and write directly to registers containing the controller's parameters. With it you could read all 141 of the controller's parameters with five read commands.

Because of the wide array of choices available for setting up a Series 97 controller, only a subset of the prompts contain parameters in a given situation. This manual explains the interrelations between prompts. A Modbus read command response of -32000 indicates that a register is not implemented; -32001, register not active; or -32002, not read accessible. A write command will return an exception response of 01 to indicate an illegal function, 02, illegal register; or 03, illegal data. If you try to write to an inactive prompt the controller will return an illegal data address message (02).

If you already have a software application that uses Modbus, you can simply skip to the Temperature/process Controller Prompt Table or the Modbus RTU Address Table in this chapter for the address information your program will need. The rest of this section on the Modbus provides information for writing a software application that uses Modbus.

Writing a Modbus Application

You need to code messages in eight-bit bytes, with no parity bit, one stop bit (8, n, 1). Negative parameter values must be written in twos complement format. Parameters are stored in two-byte registers accessed with read and write commands to a relative address.

Messages are sent in packets that are delimited by a pause at least as long as the time it takes to send 30 bits. To determine this time in seconds, divide 30 by your baud rate.

Because changing some parameters automatically changes or defaults other parameters, use the Complete Parameter Download Sequence table in this chapter to order write commands.

Using a controller address of 0x00 for a write command broadcasts that command to all the controllers in the network. This is a powerful feature if all the controllers on a network use all or most of the same parameters.

Packet Syntax

Each message packet begins with a one-byte controller address, from 0x01 to 0xF7. The second byte in the message packet identifies the message command: read (0x03 or 0x04); write (0x06 or 0x10); or loop back (0x08).

The next n bytes of the message packet contain register addresses and/or data.

The last two bytes in the message packet contain a two-byte Cyclical Redundancy Checksum (CRC) for error detection.

NOTE: For more information about communicating with Watlow controllers, go to www.watlow.com and download the **Data Communications Reference: Electronic User's Manual**. It is located under Literature, User's Manuals, English and search on *data communications reference*.

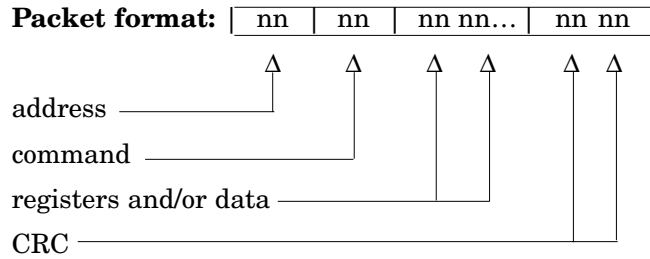

Read Multiple Registers Command (0x03 or 0x04)

This command returns from 1 to 32 registers.

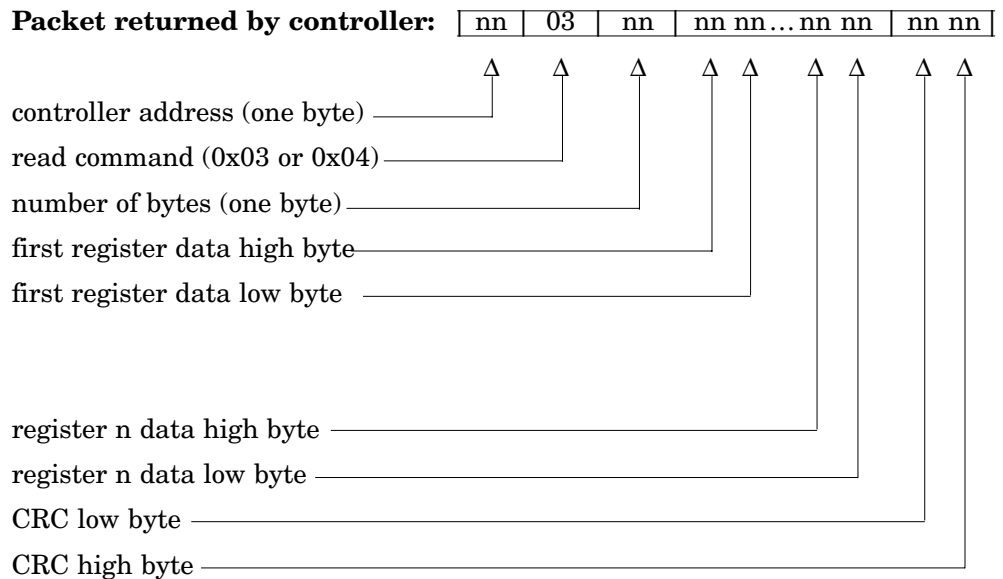
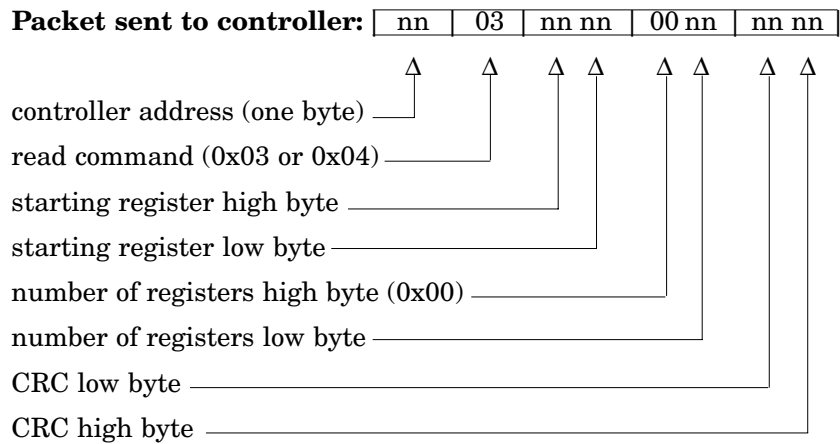

Example: Read register 0 (model number) of the controller at address 1.

Sent: 01 03 00 00 00 01 84 0A
Received: 01 03 02 00 61 79 AC
Message: 97 (0x0061).

Example: Read register 1 and 2 (Serial number 1 and Serial number 2) of controller at address 5.

Sent: 05 03 00 01 00 02 94 4F
Received: 05 03 04 00 64 00 C8 FF BA
Message: 100 (0x0064) and 200 (0x00C8).

Write to a Single Register Command (0x06)

This command writes a parameter to a single register. The controller will echo back the command. An attempt to write to a read-only parameter returns an illegal data address error (0x02).

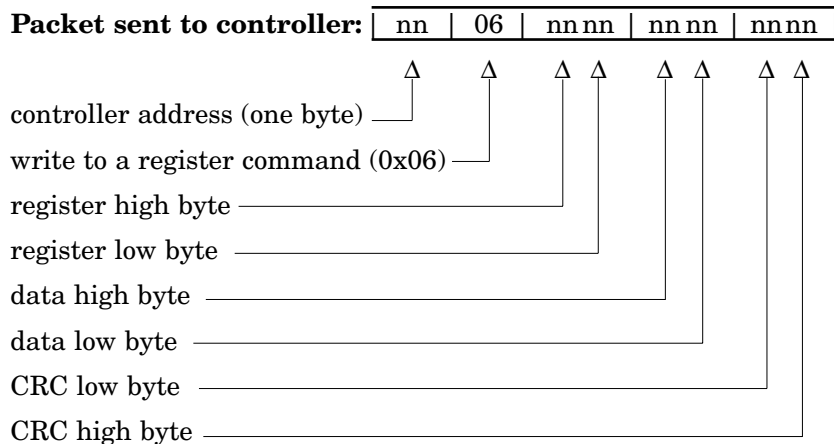

Example: Set register 702 (High limit set point) to 200 (0x00C8) on controller at address 9.

Sent: 09 06 02 BE 00 C8 E8 88
Received: 09 06 02 BE 00 C8 E8 88

Write to Multiple Registers Command (0x10)

This command actually writes a parameter to only a single register. An attempt to write to a read-only parameter returns an illegal data address error (0x02).

NOTE: For more information about communicating with Watlow controllers, go to www.watlow.com and download the Data Communications Reference: Electronic User's Manual. It is located under Literature, User's Manuals, English and search on *data communications reference*.

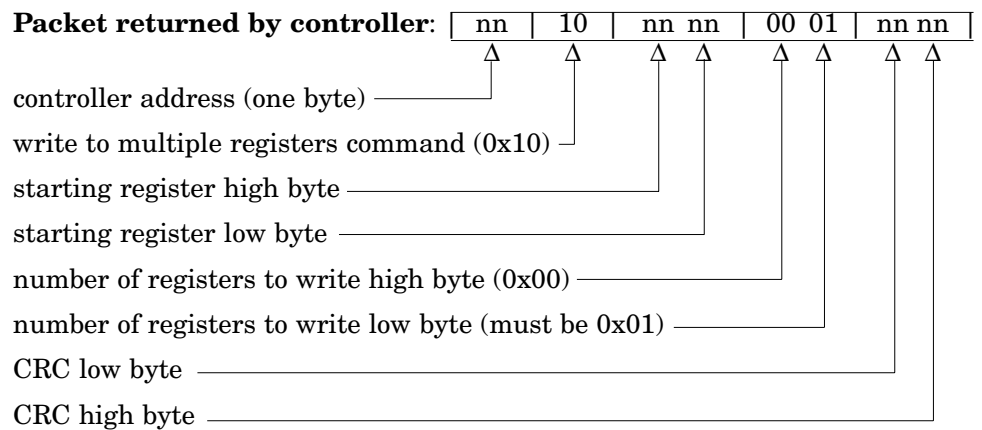
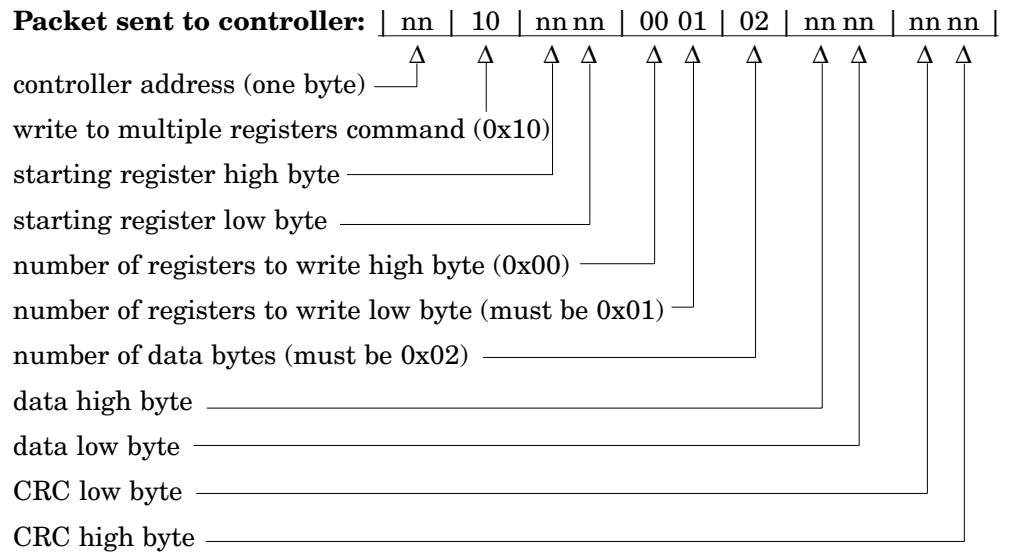

Loop Back Command (0x08)

This command simply echoes the message. This serves as a quick way to check your wiring.

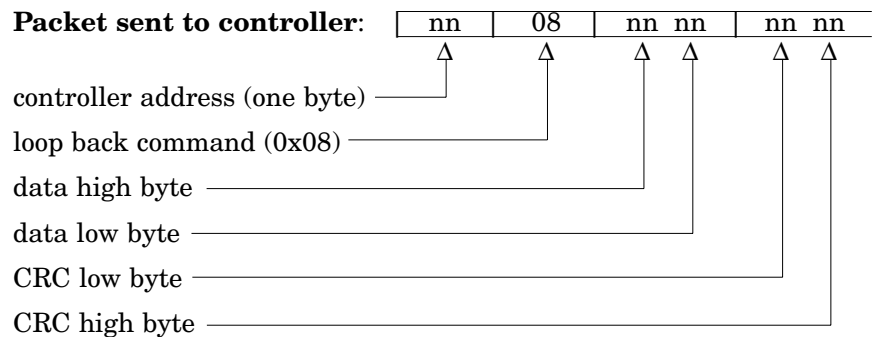

Example: Run loop back test on controller at address 40 (0x28).

Sent: 28 08 55 66 77 88 31 B7

Received: 28 08 55 66 77 88 31 B7

Exception Responses

When a controller cannot process a command it returns an exception response and sets the high bit (0x80) of the command.

0x01 illegal command

0x02 illegal data address

0x03 illegal data value

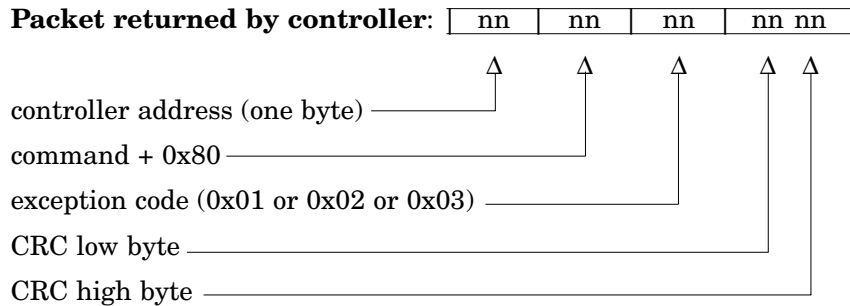

Messages with the wrong format, timing or CRC are ignored. A read command sent to an inactive parameter returns 0x0000.

Example: Exception 01 - Command 02 is not supported.

Sent: 01 02 00 01 00 02 A8 0B

Received: 01 82 01 81 60

Example: Exception 02 - The parameter at register 45 (0x002D) is inactive.

Sent: 01 06 00 2D 00 01 D8 C3

Received: 01 86 02 C3 A1

Example: Exception 03 - Cannot write 12,000 (0x2EE0) to register 7, out of range, illegal data value.

Sent: 01 06 02 59 2E E0 44 49

Received: 01 86 03 81 82

NOTE: For more information about communicating with Watlow controllers, go to www.watlow.com and download the **Data Communications Reference: Electronic User's Manual**. It is located under Literature, User's Manuals, English and search on *data communications reference*.

Cyclical Redundancy Checksum (CRC) Algorithm

This C routine, `calc_crc()`, calculates the cyclical redundancy checksum, CRC, for a string of characters. The CRC is the result of dividing the string by 0xA001. Modbus applications calculate the packet's CRC then append it to the packet.

```
#define POLYNOMIAL 0xA001;

unsigned int calc_crc(unsigned char *start_of_packet, unsigned char
*end_of_packet)
{
    unsigned int crc;
    unsigned char bit_count;
    unsigned char *char_ptr;

    /* Start at the beginning of the packet */
    char_ptr = start_of_packet;

    /* Initialize CRC */
    crc = 0xffff;

    /* Loop through the entire packet */
    do{
        /* Exclusive-OR the byte with the CRC */
        crc ^= (unsigned int)*char_ptr;

        /* Loop through all 8 data bits */
        bit_count = 0;
        do{
            /* If the LSB is 1, shift the CRC and XOR the polynomial mask with the CRC */
            if(crc & 0x0001){
                crc >>= 1;
                crc ^= POLYNOMIAL;
            }

            /* If the LSB is 0, shift the CRC only */
            else{
                crc >>= 1;
            }
        } while(bit_count++ < 7);
    } while(char_ptr++ < end_of_packet);

    return(crc);
}
```

Modbus Register Numbers

Absolute	Relative	Parameters	Absolute	Relative	Parameters
40001	0	Model Number	41402-41405	1401-1404	Upper Display User Limit Message (4 characters)
40002	1	Serial Number 1	41406	1405	Lower Display
40003	2	Serial Number 2	41407- 41410	1406-1409	Lower Display User Safe Message (4 characters)
40004	3	Software ID Number	41411-41414	1410-1413	Lower Display User Limit Message (4 characters)
40005	4	Software Revision	41501	1500	Ambient Temperature
40006	5	Date of Manufacture	41502	1501	Ambient A-D Count
40010	9	Input 2 Hardware Enabled	41505	1504	Channel 1 A-D Counts
40017	16	Output 1 Hardware	41506	1505	Channel 2 A-D Counts
40018	17	Output 2 Hardware	41514	1513	Test Display
40019	18	Output 3 Hardware	41515	1514	Test Output
40020	19	Output 4 Hardware	41516	1515	Line Frequency
40025	24	Disable Nonvolatile Memory (System)	41602	1601	Restore Factory Calibration
40101	100	Process 1	41603	1602	Default Settings
40107	106	Alarm 2 Status	14604 (1)	1603 (1)	Thermocouple Calibration, 0mV
40111	110	Alarm 3 Status	41604 (2)	1603 (2)	Thermocouple Calibration, 50mV
40115	114	Alarm 4 Status	41604 (3)	1603 (3)	Thermocouple Calibration, 32°
40202	201	Event Input Status	41604 (4)	1603 (4)	Set Ground
40320	319	Limit Status	41604 (5)	1603 (5)	Lead Resistance Calibration
40322	321	Alarm 2 Low	41604 (6)	1603 (6)	RTD Calibration 15Ω
40323	322	Alarm 2 High	41604 (7)	1603 (7)	RTD Calibration 380Ω
40341	340	Alarm 3 Low	41620	1619	Output Calibration 4, 4mA
40342	341	Alarm 3 High	41621	1620	Output Calibration 4, 20mA
40508	507	Limit Hysteresis	41622	1621	Output Calibration 4, 1V
40601	600	Sensor Type 1	41623	1622	Output Calibration 4, 10V
40602	601	Input 1	41708	1707	High Resolution
40603	602	Range Low 1			
40604	603	Range High 1			
40605	604	Input Software Filter 1			
40606	605	Calibration Offset			
40607	606	Decimal 1			
40608	607	Input Error Latching			
40612	611	Input 2			
40701	700	Limit Active Sides			
40702	701	Low Limit Set Point			
40703	702	High Limit Set Point			
40718	717	Output 2			
40721	720	Alarm Hysteresis 2			
40722	721	Latching 2			
40723	722	Silencing 2			
40724	723	Alarm Active Sides 2			
40725	724	Alarm Logic 2			
40726	725	Alarm Annunciation 2			
40735	734	Output 3			
40738	737	Alarm Hysteresis 3			
40739	738	Latching 3			
40740	739	Silencing 3			
40741	740	Alarm Active Sides 3			
40742	741	Alarm Logic 3			
40743	742	Alarm Annunciation 3			
40902	901	C or F			
41061	1060	Event Function			
41062	1061	Event Condition			
41302	1301	Operations Page Mode Lock			
41303	1302	Setup Page Lock			
41306	1305	Calibration Menu Lock			
41401	1400	Address			

Calibrating the Series 97

To enter the a calibration menu, first warm up the unit, then enter the Factory Page by holding down the Reset Key and **⊙** for six seconds. Once in the Factory Page **FctY** use the up-arrow **▲** or down-arrow **▼** key to select a menu. The last two menus on the Factory Page are Input Calibration Menu **c in 1** and Output Calibration Menu **c out**. If **0E4** is not a process output, the **c out** prompt will not appear.

You can restore the original factory calibration with Restore Factory Calibration **r 5E** (Calibration 1 Menu) or revert to the default parameter range value with Default Settings **dFLE** (Calibration 1 Menu).

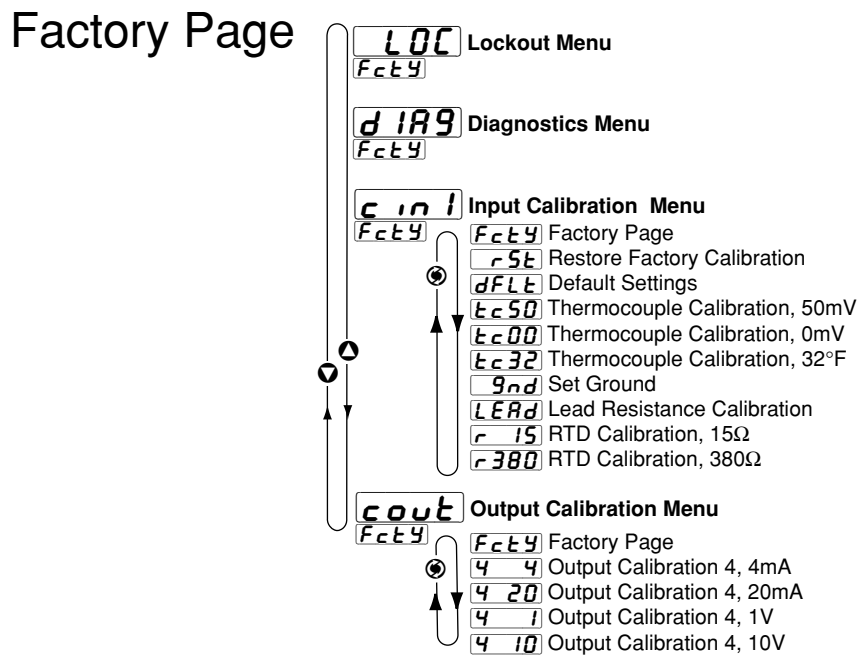

Figure A.11 — The Calibration Menus.

Thermocouple Input Procedure

Equipment

- Type J reference compensator with reference junction at 32°F/0°C, or type J thermocouple calibrator to 32°F/0°C.
- Precision millivolt source, 0 to 50mV minimum range, 0.002mV resolution.

Input 1 Setup and Calibration

1. Connect the correct power supply to terminals 8 and 9 (see Chapter Three and the Appendix).
2. Connect the millivolt source to terminals 6 (-) and 7 (+) with copper wire.
3. Enter 50.000mV from the millivolt source. Allow at least 10 seconds to stabilize. Set Thermocouple Calibration, 50mV [**EC50**] (Input Calibration Menu) to [**YES**]. Press the Advance Key **⏩** to store 50.000mV input and move to the next prompt.
4. Enter 0.000mV from the millivolt source. Allow at least 10 seconds to stabilize. Set Thermocouple Calibration, 0mV [**EC00**] (Input Calibration Menu) to [**YES**]. Press the Advance Key **⏩** to store 0.000mV input and move to the next prompt.
5. Disconnect the millivolt source and connect the reference compensator or thermocouple calibrator to terminals 6 (-) and 7 (+). With type J thermocouple wire, if using a compensator, turn it on and short the input wires. When using a type J calibrator, set it to simulate 32°F/0°C. Allow 10 seconds for the controller to stabilize. Set Thermocouple Calibration, 32° [**EC32**] (Input Calibration Menu) to [**YES**]. Press the Advance Key **⏩** to store type J thermocouple calibration and move to the next prompt.
6. Rewire for operation and verify calibration.

RTD Input Procedure

Equipment Required

- 1kΩ decade box with 0.01Ω resolution.

Input 1 Setup and Calibration

1. Connect the correct power supply to terminals 8 and 9 (see Chapter Three and the Appendix).
2. Short terminals 5, 6 and 7 together with less than 0.1Ω. Set Ground [**9nd**] (Input Calibration Menu) to [**YES**]. Press the Advance Key **⏩** to store ground input and move to the next prompt.
2. Short terminals 5 and 7 together with less than 0.5Ω. Set Lead Resistance Calibration [**LEAD**] (Input Calibration Menu) to [**YES**]. Press the Advance Key **⏩** to store the lead resistance and move to the next prompt.
4. Connect the decade box to terminals 5 (S2), 6 (S3) and 7 (S1), with 20- to 24-gauge wire.
5. Enter 15.00Ω from the decade box. Allow at least 10 seconds to stabilize. Set RTD Calibration, 15Ω [**r15**] (Input Calibration Menu) to [**YES**]. Press the Advance Key **⏩** to store the 15.00Ω input and move to the next prompt.
6. Enter 380.00Ω from the decade box. Allow at least 10 seconds to stabilize.

Set RTD Calibration, 380Ω **[380]** (Input Calibration Menu) to **[455]**. Press the Advance Key **[]** to store the 380.00Ω input and move to the next prompt.

7. Rewire for operation and verify calibration.

Process Output Procedures

Equipment

- Precision volt/ammeter with 3.5-digit resolution.

Output 4 Setup and Calibration

1. Connect the correct power supply to terminals 8 and 9 (see Chapter Three and the Appendix).

Milliamperes

2. Connect the volt/ammeter to terminals 20 (-) and 21 (+).
3. At Output Calibration 4, 4mA **[4 4]** (Output Calibration Menu) enter the reading from the ammeter. The unit should stabilize within one second. Repeat until the volt/ammeter reads 4.00mA, ±0.1mA. Press the Advance Key **[]** to store the value and move to the next prompt.
4. At Output Calibration 4, 20mA **[4 20]** (Output Calibration Menu) enter the reading from the volt/ammeter. The unit should stabilize within one second. Repeat until the ammeter reads 20.00mA, ±0.1mA. Press the Advance Key **[]** to store the value and move to the next prompt.

Volts

5. Connect the volt/ammeter to terminals 19 (+) and 20 (-).
6. At Output Calibration 4, 1V **[4 1]** (Output Calibration Menu) enter the reading from the volt/ammeter. The unit should stabilize within one second. Repeat until the voltmeter reads 1.00V, ±0.1V. Press the Advance Key **[]** to store the value and move to the next prompt.
7. At Output Calibration 4, 10V **[4 10]** (Output Calibration Menu) enter the reading from the volt/ammeter. The unit should stabilize within one second. Repeat until the volt/ammeter reads 10.00V, ±0.1V. Press the Advance Key **[]** to store the value and move to the next prompt.
8. Rewire for operation and verify calibration.

Glossary

annunciator — A visual display that uses pilot lights to indicate the former or existing condition of several items in a system.

burst fire — A power control method that repeatedly turns on and off full ac cycles. Also called zero-cross fire, it switches close to the zero-voltage point of the ac sine wave. Variable-time-base burst fire selectively holds or conducts ac cycles to achieve the desired power level. See zero cross.

calibration offset — An adjustment to eliminate the difference between the indicated value and the actual process value.

CJC — see cold junction compensation.

closed loop — A control system that uses a sensor to measure a process variable and makes decisions based on that feedback.

cold junction — see junction, cold.

cold junction compensation — Electronic means to compensate for the effective temperature at the cold junction.

default parameters — The programmed instructions that are permanently stored in the microprocessor software.

derivative — The rate of change in a process variable. Also known as rate. See PID.

derivative control (D) — The last term in the PID control algorithm. Action that anticipates the rate of change of the process, and compensates to minimize overshoot and undershoot. Derivative control is an instantaneous change of the control output in the same direction as the proportional error. This is caused by a change in the process variable (PV) that decreases over the time of the derivative (TD). The TD is in units of seconds.

Deutsche Industrial Norm (DIN) — A set of technical, scientific and dimensional standards developed in Germany. Many DIN standards have worldwide recognition.

DIN — See Deutsche Industrial Norm.

droop — In proportional controllers, the difference between set point and actual value after the system stabilizes.

duty cycle — The percentage of a cycle time in which the output is on.

external transmitter power supply — A dc voltage source that powers external devices.

filter, digital (DF) — A filter that slows the response of a system when inputs change unrealistically or too fast. Equivalent to a standard resistor-capacitor (RC) filter.

form A — A single-pole, single-throw relay that uses only the normally open (NO) and common contacts. These contacts close when the relay coil is energized. They open when power is removed from the coil.

form B — A single-pole, single-throw relay that uses only the normally closed (NC) and common contacts. These contacts open when the relay coil is energized. They close when power is removed from the coil.

form C — A single-pole, double-throw relay that uses the normally open (NO), normally closed (NC) and common contacts. The operator can choose to wire for a form A or form B contact.

hysteresis — A change in the process variable required to re-energize the control or alarm output. Sometimes called switching differential.

integral — Control action that automatically eliminates offset, or droop, between set point and actual process temperature. See auto-reset.

integral control (I) — A form of temperature control. The I of PID. See integral.

isolation — Electrical separation of sensor from high voltage circuitry. Allows use of grounded or ungrounded sensing element.

Joint Industrial Standards (JIS) — A Japanese agency that establishes and maintains standards for equipment and components. Also known as JISC (Japanese Industrial Standards Committee), its function is similar to Germany's Deutsche Industrial Norm (DIN).

junction, cold — Connection point between thermocouple metals and the electronic instrument. See junction, reference.

junction, reference — The junction in a thermocouple circuit held at a stable, known temperature (cold junction). Standard reference temperature is 32°F (0°C).

Modbus™ — A digital communications protocol owned by AEG Schneider Automation for industrial computer networks.

Modbus™ RTU — Remote Terminal Unit, an individual Modbus™-capable device on a network.

NEMA 4X — A NEMA specification for determining resistance to moisture infiltration. This rating certifies the controller as washable and corrosion resistant.

on/off controller — A temperature controller that operates in either full on or full off modes.

open loop — A control system with no sensory feedback.

output — Control signal action in response to the difference between set point and process variable.

overshoot — The amount by which a process variable exceeds the set point before it stabilizes.

P control — Proportioning control.

PD control — Proportioning control with derivative (rate) action.

PDR control — Proportional derivative control with manual reset, used in fast responding systems where the reset causes instabilities. With PDR control, an operator can enter a manual reset value that eliminates droop in the system.

PI control — Proportioning control with integral (auto-reset) action.

PID — Proportional, integral, derivative. A control mode with three functions: proportional action dampens the system response, integral corrects for droop, and derivative prevents overshoot and undershoot.

proportional — Output effort proportional to the error from set point. For example, if the proportional band is 20° and the process is 10° below set point, the heat proportioned effort is 50 percent. The lower the PB value, the higher the gain.

proportional band (PB) — A range in which the proportioning function of the control is active. Expressed in units, degrees or percent of span. See PID.

proportional control — A control using only the P (proportional) value of PID control.

range — The area between two limits in which a quantity or value is measured. It is usually described in terms of lower and upper limits.

rate — Anticipatory action that is based on the rate of temperature change, and compensates to minimize overshoot and undershoot. See derivative.

rate band — A range in which the rate function of a controller is active. Expressed in multiples of the proportional band. See PID.

reference junction — see junction, reference.

remote — A controller that receives its set point signal from another device called the master.

remote set point — A signal that indicates the set point for the process, and is sent from another device.

reset — Control action that automatically eliminates offset, or droop, between set point and actual process temperature. Also see integral.

automatic reset — The integral function of a PI or PID temperature controller that adjusts the process temperature to the set point after the system stabilizes. The inverse of integral.

automatic power reset — A feature in latching limit controls that does not recognize power outage as a limit condition. When power is restored, the output is re-energized automatically, as long as the temperature is within limits.

manual reset — 1) A feature on a limit control that requires human intervention to return the limit to normal operation after a limit condition has occurred. 2) The adjustment of a proportional control to raise the proportional band to compensate for droop.

resistance temperature detector (RTD) — A sensor that uses the resistance temperature characteristic to measure temperature. There are two basic types of RTDs: the wire RTD, which is usually made of platinum, and the thermistor, which is made of a semiconductor material. The wire RTD is a positive temperature coefficient sensor only, while the thermistor can have either a negative or positive temperature coefficient.

RTD — See resistance temperature detector.

thermal system — A regulated environment that consists of a heat source, heat transfer medium or load, sensing device and a control instrument.

thermocouple (t/c) — A temperature sensing device made by joining two dissimilar metals. This junction produces an electrical voltage in proportion to the difference in temperature between the hot junction (sensing junction) and the lead wire connection to the instrument (cold junction).

thermocouple break protection — The ability of a control to detect a break in the thermocouple circuit and take a predetermined action.

three-mode control — Proportioning control with integral (reset) and derivative (rate). Also see PID.

time proportioning control — A method of controlling power by varying the on/off duty cycle of an output. This variance is proportional to the difference between the set point and the actual process temperature.

transmitter — A device that transmits temperature data from either a thermocouple or a resistance temperature detector (RTD) by way of a two-wire loop. The loop has an external power supply. The transmitter acts as a variable resistor with respect to its input signal. Transmitters are desirable when long lead or extension wires produce unacceptable signal degradation.

WatLink — A Watlow software application for configuring and communication with Watlow controllers via a EIA-485 network and a Microsoft Windows-compatible personal computer.

zero cross — Action that provides output switching only at or near the zero-voltage crossing points of the ac sine wave. See burst fire.

zero switching — See zero cross.

Specifications

(2195)

Controller

- Microprocessor-based, user selectable control modes
- Input sample period; Single input 10Hz (100 msec), dual input 5Hz (200 msec) digital filter adjustable
- Display update; 2Hz (500 msec), time filter adjustable
- Input/Output/Communication isolation
- Displayed in °C or °F

Operator Interface

- Dual 4-digit LED displays: upper 10.2 mm (0.4 in), lower 6.2 mm (0.244 in)
- Advance, Up Arrow, Down Arrow, Reset tactile keys

Standard Conditions For Specifications

- Ambient temperature 25°C/77°F ±3°C, rated line voltage, 50 to 60Hz, 0 to 90% RH non-condensing, 15 minute warm-up

Universal Input 1

Thermocouple

- Type J, K, T, N, C (W5), E, PTII, D (W3), B, R, S thermocouple types
- >20MΩ input impedance
- Maximum 20Ω source resistance
- 30mA open detection bias

RTD

- 2- or 3-wire platinum, 100Ω
- DIN and JIS curves
- Whole or tenth degree indication
- 150μA nominal RTD excitation current

Input 2

Event Input

- Contact or voltage
- 20KΩ input impedance
- Voltage input: event high state 3 to 36V_{DC} (dc), event low state 0 to 2V_{DC} (dc)
- Resistance/contact input: event high state > 23kΩ, event low state 0 to 2kΩ

Output Types

Open Collector/Switched DC

- Open collector configuration:
 - Maximum voltage 42V_{DC} (dc)
 - Maximum current 200mA
 - Maximum "on" resistance 1.1Ω
 - Maximum offstate leakage current 100μA
- Switched dc configuration:
 - Switched dc supply voltage 22 to 28V_{DC} (dc)
 - dc supply current limited to 30mA

Solid-state Relay

- Optically isolated
- Zero cross switched
- Without contact suppression
- Minimum load current 0.5mA rms
- Maximum current 0.5A rms at 20 to 280V~ (ac)
- Maximum offstate leakage current 10μA rms
- For resistive loads only, must use RC suppression for inductive loads

Electromechanical Relay

- Form C contact configuration
- Minimum load current 10mA @ 5V_{DC} (dc)
- Rated resistive and inductive loads: 2A @ 250V~ (ac) or 30V_{DC} (dc) maximum
- Electrical life 100,000 cycles at rated current
- For resistive loads only, must use RC suppression for inductive loads

Retransmit

- Range selectable: 0-20mA, 4-20mA, 0-5V_{DC} (dc), 1-5V_{DC} (dc), 0-10V_{DC} (dc)
- 0 to 10V_{DC} (dc) voltage output into a 1,000Ω minimum load resistance
- 0 to 20mA current output into an 800Ω maximum load resistance
- Resolution:
 - dc ranges = 2.5mV nominal
 - mA ranges = 5μA nominal
- Calibration accuracy:
 - dc ranges = ±15mV
 - mA ranges = ±30μA
- Temperature stability 100ppm/°C

Communications

- EIA/TIA-485, EIA/TIA-232
- Opto-isolated
- Modbus™ RTU protocol
- 1200, 2400, 4800, 9600, 19200 baud rates
- 32 maximum units can be connected (With additional 485 repeater hardware, up to 247 units may be connected)

Accuracy

- Input ranges

Type J:	32 to 1382°F	or	0 to 750°C
Type K:	-328 to 2282°F	or	-200 to 1250°C
Type T:	-328 to 662°F	or	-200 to 350°C
Type N:	32 to 2282°F	or	0 to 1250°C
Type E:	-328 to 1470°F	or	-200 to 900°C
Type C(W5):	32 to 4200°F	or	0 to 2315°C
Type D(W3):	32 to 4200°F	or	0 to 2315°C
Type PTII:	32 to 2540°F	or	0 to 1393°C
Type R:	32 to 2642°F	or	0 to 1450°C
Type S:	32 to 2642°F	or	0 to 1450°C
Type B:	1598 to 3092°F	or	870 to 1700°C
DIN:	-328 to 1472°F	or	-200 to 800°C
JIS:	-328 to 1166°F	or	-200 to 630°C

Thermocouple Inputs

- Calibration accuracy ±0.1% of span ±1°C at standard conditions
Exceptions:
 - Type T; 0.12% of span for -200°C to -50°C,
 - Types R and S; 0.15% of span for 0°C to 100°C
 - Types B; 0.24% of span for 870°C to 1700°C
- Accuracy span: 540°C/1000°F minimum
- Temperature stability: ±0.1 degree per degree change in ambient

RTD Inputs

- Calibration accuracy $\pm 0.1\%$ of span $\pm 1^\circ\text{C}$ at standard conditions
- Accuracy span: $540^\circ\text{C}/1000^\circ\text{F}$ minimum
- Temperature stability: ± 0.05 degree per degree change in ambient

Agency Approvals

- FM Class 3545 File J.I. 1B5A6.AF, Temperature Limit Switches, Indicating
- CE EN 61326 Industrial Immunity, Class A emissions and EN61010-1 Safety standard.
- IP65, UL 50 Recognized Enclosure (Nema 4X & 12)

Terminals

- Touch safe
- 22 to 12 AWG

Power

- 100-240V~ (ac) +10%, -15%; 50/60Hz, $\pm 5\%$
- 24-28V~ (ac) or V= (dc) +10%, -15%; 50/60Hz, $\pm 5\%$
- 7.0 VA maximum power consumption
- Data retention upon power failure via nonvolatile memory

Operating Environment

- 0 to 65°C , 32 to 149°F
- 0 to 90% RH, non-condensing
- Storage temperature: -40 to 85°C , -40 to 185°F

Dimensions

- Width 52 mm or 2.05 in
- Height 52 mm or 2.05 in
- Length 107 mm or 4.2 in
- Depth behind panel surface 98.4 mm or 3.875 in
- Approximate controller weight 0.2 kg (0.4 lbs)

Allowable Operating Ranges

Type J:	1.0	32	to	1500°F	or	0	to	815°C
	0.1	32.0	to	999.9°F	or	0.0	to	815.0°C
Type K:	1.0	-454°F	to	2500°F	or	-270°C	to	1370°C
	0.1	-199.9	to	999.9°F	or	-199.9	to	999.9°C
Type T:	1.0	-454°F	to	750°F	or	-270°C	to	400°C
	0.1	-199.9	to	750.0°F	or	-199.9	to	400.0°C
Type N:	1.0	32	to	2372°F	or	0	to	1300°C
	0.1	32.0	to	999.9°F	or	0.0	to	999.9°C
Type E:	1.0	-454°F	to	1470°F	or	-270°C	to	800°C
	0.1	-199.9	to	999.9°F	or	-199.9	to	800.0°C
Type C:	1.0	32	to	4200°F	or	0	to	2315°C
	0.1	32.0	to	999.9°F	or	0.0	to	999.9°C
Type D:	1.0	32	to	4200°F	or	0	to	2315°C
	0.1	32.0	to	999.9°F	or	0.0	to	999.9°C
Type PTII:	1.0	32	to	2543°F	or	0	to	1395°C
	0.1	32.0	to	999.9°F	or	0.0	to	999.9°C
Type R:	1.0	32	to	3200°F	or	0	to	1760°C
Type S:	1.0	32	to	3200°F	or	0	to	1760°C
Type B:	1.0	32	to	3300°F	or	0	to	1816°C
DIN	1.0	-328	to	1472°F	or	-200	to	800°C
	0.1	-199.9	to	999.9°F	or	-199.9	to	800.0°C
JIS	1.0	-328	to	1166°F	or	-200	to	630°C
	0.1	-199.9	to	999.9°F	or	-199.9	to	630.0°C

Note: These specifications are subject to change without prior notice.

Modbus™ is a trademark of AEG Schneider Automation.

UL® is a registered trademark of the Underwriter's Laboratories, Inc.

Functionality Matrix

	Universal Input	Event	High Low Limit	High Low Alarm	Retransmit	232 485 Comm
Input 1						
Input 2						
Output 1						
Output 2						
Output 3						
Output 4						

Ordering Information

(1635)

Series 97

97

Microprocessor-based $\frac{1}{16}$ DIN with thermocouple and RTD input 1. Options include: software, power supply, input 2, four outputs and display color

Power Supply

- A = 100-240V~ (ac)
- B = 24-28V~ (ac/dc)

Input 2

- 0 = None
- 1 = Event input

Output 1

- D = Electromechanical relay, Form C, 2A, without RC suppression

Output 2

- A = None
- C = Switched dc output/open collector
- D = Electromechanical relay, Form C, 2A, without RC suppression
- K = 0.5A solid-state relay without RC suppression

Output 3

- A = None
- D = Electromechanical relay, Form C, 2A, without RC suppression

Output 4

- A = None
- D = Electromechanical relay, Form C, 2A, without RC suppression
- R = 232 Communications
- U = 485 Communications
- M = Universal Retransmit, range selectable: 0-20mA, 4-20mA, 0-5V \approx (dc), 1-5V \approx (dc), 0-10V \approx (dc)

Software/Preset Parameters

- 00 = Standard software

Display/Overlay

- Upper/Lower
- RR = Red/Red display
- RG = Red/Green display
- GR = Green/Red display
- GG = Green/Green display

Index

A

- Address 6.14
- Alarm 2 Low 6.5
- Alarm 2 High 6.5
- Alarm 2 Status 6.4
- Alarm 2 Type 6.10
- Alarm 3 Low 6.5
- Alarm 3 High 6.6
- Alarm 3 Status 6.4
- Alarm 3 Type 6.11
- Alarm 4 Low 6.6
- Alarm 4 High 6.6
- Alarm 4 Status 6.4
- Alarm 4 Type 6.12
- Alarm 5.8-5.11
 - hysteresis 5.8
 - latching 5.9
 - process 5.9
 - set points 5.8
 - silencing 5.10
- Alarm Active Sides 2 6.10
- Alarm Active Sides 3 6.11
- Alarm Active Sides 4 6.12
- Alarm Annunciation 2 6.10
- Alarm Annunciation 3 6.12
- Alarm Annunciation 4 6.13
- Alarm Hysteresis 2 6.10
- Alarm Hysteresis 3 6.11
- Alarm Hysteresis 4 6.12
- Alarm Logic 2 6.10
- Alarm Logic 3 6.11
- Alarm Logic 4 6.13
- Alarm Menu 6.5-6.6
- Ambient A-D Counts 6.19
- Ambient Temperature 6.19
- Analog Output 4 6.13
- Analog Output High 6.13
- Analog Output Low 6.13
- Analog Output Offset 6.13

B

- Baud Rate 6.13

C

- C or F 6.16
- Calibrating A.11-A.13
 - Process Output A.13
 - RTD Input A.12
 - Thermocouple Input A.12

- Calibration Menu Lock 6.17
- Calibration Offset 5.3, 6.5
- Channel 1 A-D Counts 6.19
- Channel 2 A-D Counts 6.19
- configure the controller 4.6
- communications 5.11
 - and retransmit option 3.10
- converting between EIA-232 and EIA-435 3.11
- customer feedback inside front cover
- cyclical redundancy checksum (CRC) algorithm A.9

D

- Date of Manufacture 6.17
- Decimal 1 6.8
- Default Settings 6.20
- Diagnostics Menu 6.17-6.19
- Digital event, wiring 3.6
- Display Menu 6.14-6.16

E

- EIA Conversion 3.11
- Errors, troubleshooting A.2-A.3
- Event Condition 6.9
- Event Function 6.9
- Event Input 5.6
- Event Input Status 6.4
- exception responses A.8

F

- Factory Page 4.5
- Factory Page menus 6.17-6.21
- filter time constant 5.4

G

- gap dimensions 2.2
- Global Menu 6.16

H

- High Limit Set Point 6.5
- High Resolution 6.19
- Home Page 4.4, 6.3

I J

- Input 1 6.7
- Input 2 6.9
- Input 2 Hardware Enabled 6.18
- Input 1 Menu 6.7-6.8
- Input 2 Menu 6.9

- Input Calibration Menu 6.19-6.21, A.12
- Input Error Latching 6.16
- Inputs and outputs 1.1
- Input Software Filter 1 6.8
- Input-to-output isolation 3.2
- Input wiring
 - digital event 3.6
 - RTD 3.6
 - thermocouple 3.6
- Installation 2.1-2.2
- Installation sensor 3.3
- Isolation blocks 3.2

K

- Keys and displays 4.2

L

- Latching 2 6.10
- Latching 3 6.11
- Latching 4 6.12
- Lead Resistance Calibration 6.20
- Limit Active Sides 6.9
- Limit Hysteresis 6.9
- Limit Menu 6.5
- Limit Status 6.4
- Line Frequency 6.19
- Lockout Menu 6.17
- Loop back command A.7
- Lower Display 6.14
- Lower Display User Limit Message 6.16
- Lower Display User Safe Message 6.15
- Low Limit Set Point 6.5

M

- Modbus Remote Terminal Unit (RTU) A.4
- Model Number 6.17
- Monitor Menu 6.4
- Multiple registers command
 - read A.5
 - write A.6

N

- Navigation
 - map 4.4-4.5
 - and Software 4.1-4.7
 - tasks for users 4.6-4.7

O

- Operations Page 4.4
- Operations Page menus 6.4-6.6
- Operations Page Mode Lock 6.17
- ordering information A.20
- Output 2 6.9
- Output 3 6.11
- Output 4 6.12
- Output 1 Hardware 6.18
- Output 2 Hardware 6.18
- Output 3 Hardware 6.18
- Output 4 Hardware 6.18
- Output 1 Menu 6.9
- Output 2 Menu 6.9-6.11
- Output 3 Menu 6.11-6.12
- Output 4 Menu 6.12-6.14
- Output Calibration Menu 6.21, A.11
- output wiring
 - AC 3.7-3.10
 - communications and retransmit option 3.10
 - switched DC, open collector 3.8

P Q

- packet syntax A.4
- panel cutout dimensions 2.1
- parameter setup order 6.2, A.25
- power wiring 3.3
- Process 1 6.4
- Process 4 Type 6.13

R

- Range Low and Range High 5.5
- Range High 1 6.8
- Range Low 1 6.8
- Remote Terminal Unit (RTU) A.4
- removing controller 2.3
- Restore Factory Calibration 6.20
- retransmit 5.7
- RTD Calibration, 15 Ω 6.20
- RTD Calibration, 380 Ω 6.20
- RTD input wiring 3.3, 3.6

S

- safety information inside front cover
- sensor
 - installation 3.3
 - selection 5.5
- Sensor Type 1 6.7

- Serial Number 1 6.18
- Serial Number 2 6.18
- Set Ground 6.20
- Setup Page 4.5
- Setup Page Lock 6.17
- Setup Page menus 6.7-6.16
- setup steps 1.2
- Silencing 2 6.10
- Silencing 3 6.11
- Silencing 4 6.12
- single register command, write A.6
- Software ID Number 6.18
- Software Map 4.4-4.5, A.26
- Software Revision 6.18
- specifications A.18-A.19

T

- technical assistance inside front cover
- Test Display 6.19
- Test Output 6.19
- Thermocouple Calibration, 0mV 6.20
- Thermocouple Calibration, 32 $^{\circ}$ 6.20
- Thermocouple Calibration, 50mV 6.20
- thermocouple input wiring 3.3
- troubleshooting alarms and errors A.2-A.3

U V

- Upper Display 6.14
- Upper Display User Limit Message 6.15

W X Y Z

- warranty information back cover
- wiring 3.2-3.10
 - Input 1 3.6
 - Input 2 3.6
 - Output 1 3.7
 - Output 2 3.8
 - Output 3 3.9
 - Output 4 3.10
- wiring example 3.4
- wiring notes 3.5

Prompt Index

- 4 1** Output Calibration 4, 1V 6.21
- 4 4** Output Calibration 4, 4mA 6.21
- 4 10** Output Calibration 4, 10V 6.21
- 4 20** Output Calibration 4, 20mA 6.21

A

- A2h1** Alarm 2 High 6.5
- A2Lo** Alarm 2 Low 6.5
- A3h1** Alarm 3 High 6.6
- A3Lo** Alarm 3 Low 6.5
- A4h1** Alarm 4 High 6.6
- A4Lo** Alarm 4 Low 6.6
- ARAL** Analog Output Offset 6.13
- Acnt** Ambient A-D Counts 6.19
- Addr** Address 6.14
- Ah1** Analog Output High 6.14
- AL2** Alarm 2 Status 6.4
- AL3** Alarm 3 Status 6.4
- AL4** Alarm 4 Status 6.4
- ALP7** Alarm Menu 6.5-6.6
- ALo** Analog Output Low 6.13
- AP7b** Ambient Temperature 6.19
- Anu2** Alarm Annunciation 2 6.11
- Anu3** Alarm Annunciation 3 6.12
- Anu4** Alarm Annunciation 4 6.13
- Aout** Analog Output 4 6.13

B

- bAUD** Baud Rate 6.13

C

- CAL** Calibration Menu Lock 6.17
- CAL1** Calibration Offset 6.5
- cin1** Input Calibration Menu A.11
- C-F** C or F 6.16
- cnt1** Channel 1 A-D Counts 6.19
- cnt2** Channel 2 A-D Counts 6.19
- cout** Output Calibration Menu A.11

D

- dAEE** Date of Manufacture 6.17
- DEC1** Decimal 1 6.8
- DFLE** Default Settings 6.20
- dIAG** Diagnostics Menu 6.17-6.19
- dISP** Display Menu 6.14-6.16
- dISP** Test Display 6.19

E

- Ecn** Event Condition 6.9
- Efn** Event Function 6.9
- Err** Input Error Latching 6.16
- ESt** Event Input Status 6.4

F

- FctY** Factory Page menus 6.17-6.21
- Ftr1** Input Software Filter 1 6.8

G

- gLBL** Global Menu 6.16
- gnd** Set Ground 6.20

H

- hrES** High Resolution 6.19
- hYS2** Alarm Hysteresis 2 6.10
- hYS3** Alarm Hysteresis 3 6.11
- hYS4** Alarm Hysteresis 4 6.12

IJK

- in1** Input 1 6.7
- in2** Input 2 6.9
- inP1** Input 1 Menu 6.7-6.8
- inP2** Input 2 Menu 6.9
- IEY2** Input 2 Hardware Enabled 6.18

L

- LAE2** Latching 2 6.10
- LAE3** Latching 3 6.11
- LAE4** Latching 4 6.12
- LdSP** Lower Display 6.16
- LEAd** Lead Resistance Calibration 6.20
- L9c2** Alarm Logic 2 6.10
- L9c3** Alarm Logic 3 6.11
- L9c4** Alarm Logic 4 6.13
- Lh1** High Limit Set Point 6.5
- LhYS** Limit Hysteresis 6.9
- Lm7** Limit Menu 6.5
- Line** Line Frequency 6.19
- LLo** Low Limit Set Point 6.5
- LOC** Lockout Menu 6.17
- LoL** Lower Display User Limit Message 6.16
- LoS** Lower Display User Safe Message 6.16
- LSid** Limit Active Sides 6.9
- LSt** Limit Status 6.4

MN

- M7dL** Model Number 6.17
- M7on** Monitor Menu 6.4

O

- OPER** Operations Page menus 6.4-6.6
- OPER** Operations Page Mode Lock 6.17
- OEY1** Output 1 Hardware 6.18
- OEY2** Output 2 Hardware 6.18
- OEY3** Output 3 Hardware 6.18
- OEY4** Output 4 Hardware 6.18
- OE2** Output 2 6.9
- OE3** Output 3 6.11
- OE4** Output 4 6.12
- Oue1** Output 1 Menu 6.9
- Oue2** Output 2 Menu 6.9-6.11
- Oue3** Output 3 Menu 6.11-6.12
- Oue4** Output 4 Menu 6.12-6.14

PQ

- Pr1** Process 1 6.4
- PrC4** Process 4 Type 6.13

R

- r15** RTD Calibration, 15Ω 6.20
- r380** RTD Calibration, 380Ω 6.20
- REu** Software Revision 6.18
- rh1** Range High 1 6.8
- rL1** Range Low 1 6.8
- rSt** Restore Factory Calibration 6.20

S

- SEn1** Sensor Type 1 6.7
- SEt** Setup Page menus 6.7-6.16
- SEt** Setup Page Lock 6.17
- Sid2** Alarm Active Sides 2 6.10
- Sid3** Alarm Active Sides 3 6.11
- Sid4** Alarm Active Sides 4 6.12
- SIL2** Silencing 2 6.10
- SIL3** Silencing 3 6.11
- SIL4** Silencing 4 6.12
- Sn1** Serial Number 1 6.18
- Sn2** Serial Number 2 6.18
- SoFE** Software ID Number 6.18

T

- tc00** Thermocouple Calibration, 0mV 6.20
- tc32** Thermocouple Calibration, 32° 6.20
- tc50** Thermocouple Calibration, 50mV 6.20
- toUt** Test Output 6.19
- TSht** Communications Test/ Troubleshooting 6.19

UVWXYZ

- UdSP** Upper Display 6.14

UP L Upper Display User Limit Message 6.15

Declaration of Conformity

Series 97

WATLOW Winona, Inc.
1241 Bundy Boulevard
Winona, Minnesota 55987 USA



Declares that the following product:

English

Designation: Series 97
Model Number(s): 97(A or B) (0 or 1) - D (A, C, D or K) (A or D) (A, D, R, U or M) - (Any four letters or numbers)
Classification: Temperature control, Installation Category II, Pollution degree 2
Rated Voltage: 100 to 240V~ (ac) or 24 to 28V~ (ac or dc)
Rated Frequency: 50 or 60 Hz
Rated Power Consumption: 7VA maximum

Meets the essential requirements of the following European Union Directives by using the relevant standards show below to indicate compliance.

89/336/EEC Electromagnetic Compatibility Directive EN 61326:1997 With A1:1998 – Electrical equipment for measurement, control and laboratory use – EMC requirements (Industrial Immunity, Class A Emissions).

EN 61000-4-2:1996 With A1, 1998 – Electrostatic Discharge Immunity
EN 61000-4-3:1997 – Radiated Field Immunity
EN 61000-4-4:1995 – Electrical Fast-Transient / Burst Immunity
EN 61000-4-5:1995 With A1, 1996 – Surge Immunity
EN 61000-4-6:1996 – Conducted Immunity
EN 61000-4-11:1994 Voltage Dips, Short Interruptions and Voltage Variations Immunity
EN 61000-3-2:1995 With A1-3:1999 – Harmonic Current Emissions
EN 61000-3-3:1995 With A1:1998 – Voltage Fluctuations and Flicker

73/23/EEC Low-Voltage Directive EN 61010-1:1993 With A1:1995 Safety Requirements of electrical equipment for measurement, control and laboratory use. Part 1: General requirements

Déclare que le produit suivant :

Français

Désignation: Série 97
Numéro(s) de modèle(s): 97 (A ou B) (0 ou 1) - D (A, C, D ou K) (A ou D) (A, D, R, U ou M) - (quatre chiffres ou lettres quelconques)
Classification: Composant de sécurité (limiteur de température), installation catégorie II, degré de pollution 2
Tension nominale: 100 à 240 V~ (c.a) ou 24 à 28 V~ (c.a ou c.c)
Fréquence nominale: 50 ou 60 Hz
Consommation d'alimentation nominale: 7 VA maximum

Répond aux normes essentielles des directives suivantes de l'Union européenne en utilisant les standards normalisés ci-dessous qui expliquent les normes auxquelles répondre :

Directive 89/336/CEE sur la compatibilité électromagnétique EN 61326:1997 avec A1 :1998 – Matériel électrique destiné à l'étalonnage, au contrôle et à l'utilisation en laboratoire – Exigences CEM (Immunité industrielle, Émissions de catégorie A).

EN 61000-4-2:1996 Avec A1, 1998 – Immunité aux décharges électrostatiques
EN 61000-4-3:1997 – Immunité aux champs de radiation
EN 61000-4-4:1995 – Immunité contre les surtensions électriques rapides/ Rafale
EN 61000-4-5:1995 avec A1, 1996 – Immunité contre les surtensions
EN 61000-4-6:1996 – Immunité conduite
EN 61000-4-11:1994 Immunité contre les écarts de tension, interruptions courtes et variations de tension
EN 61000-3-2:1995 avec A1-3 :1999 – Emissions de courant harmoniques
EN 61000-3-3:1995 avec A1 :1998 – Fluctuations et vacillements de tension

Directive 73/23/CEE sur les basses tensions EN 61010-1:1993 avec A1 :1995 Normes de sécurité du matériel électrique pour la mesure, le contrôle et l'utilisation en laboratoire. 1ère partie : Conditions générales

Erklärt, daß das folgende Produkt:

Deutsch

Beschreibung: Serie 97
Modellnummer(n): 97(A oder B)(0 oder 1) – D (A, C, D oder K)(A oder D)(A, D, R, U oder M) - (4 beliebige Buchstaben oder Ziffern)
Klassifikation: Temperaturregler, Installationskategorie II, Verschmutzungsgrad 2
Nennspannung: 100 bis 240 V~ (AC) oder 24 bis 28 V~ (AC oder DC)
Nennfrequenz: 50 oder 60 Hz
Nominaler Stromverbrauch: Max. 7 VA

Erfüllt die wichtigsten Normen der folgenden Anweisung(en) der Europäischen Union unter Verwendung des wichtigsten Abschnitts bzw. der wichtigsten Abschnitte die unten zur Befolgung aufgezeigt werden.

89/336/EEC Elektromagnetische Kompatibilitätsrichtlinie EN 61326:1997 mit A1:1998 – Elektrisches Gerät für Messung, Kontrolle und Laborgebrauch – EMV-Anforderungen (Störfestigkeit Industriebereich, Klasse A Emissionen)

EN 61000-4-2:1996 mit A1, 1998 – Störfestigkeit gegen elektronische Entladung
EN 61000-4-3:1997 – Störfestigkeit gegen Strahlungsfelder
EN 61000-4-4:1995 – Störfestigkeit gegen schnelle Stöße/Burst
EN 61000-4-5:1995 mit A1, 1996 – Störfestigkeit gegen Überspannung
EN 61000-4-6:1996 – Geleitete Störfestigkeit
EN 61000-4-11:1994 Störfestigkeit gegen Spannungsabfall, kurze Unterbrechungen und Spannungsschwankungen
EN 61000-3-2:1995 mit A1-3:1999 – Harmonische Stromemissionen
EN 61000-3-3:1995 mit A1:1998 – Spannungsfuktationen und Flimmern

73/23/EEC Niederspannungsrichtlinie EN 61010-1:1993 mit A1:1995 Sicherheitsanforderungen für elektrische Geräte für Messungen, Kontrolle und Laborgebrauch. Teil 1: Allgemeine Anforderungen

Declara que el producto siguiente:

Español

Designación: Serie 97
Números de modelo: 97 (A o B)(0 ó 1) - D(A, C, D o K)(A o D)(A, D, R, U o M) - (Cualquier combinación de cuatro números y letras)
Clasificación: Control de temperatura, Categoría de instalación II, Grado de contaminación 2
Tensión nominal: 100 a 240V~ (CA) o 24 a 28 V~ (CA o CD)
Frecuencia nominal: 50 o 60 Hz
Consumo nominalde energía: 7 VA máximo

Cumple con los requisitos esenciales de las siguientes Directrices de la Unión Europea mediante el uso de las normas aplicables que se muestran a continuación para indicar su conformidad.

89/336/EEC Directriz de compatibilidad electromagnética EN 61326:1997 CON A1:1998.– Equipo eléctrico para medición, control y uso en laboratorio – Requisitos EMC (Inmunidad industrial, Emisiones Clase A).

EN 61000-4-2:1996 con A1, 1998 – Inmunidad a descarga electrostática
EN 61000-4-3:1997 – Inmunidad a campo radiado
EN 61000-4-4:1995 – Inmunidad a incremento repentino/rápidas fluctuaciones eléctricas transitorias
EN 61000-4-5:1995 con A1, 1996 – Inmunidad a picos de voltaje o corriente
EN 61000-4-6:1996 – Inmunidad por conducción
EN 61000-4-11:1994 Inmunidad a caídas de voltaje, variaciones y pequeñas interrupciones de voltaje
EN 61000-3-2:1995 con A1-3:1999 – Emisiones de corriente armónica
EN 61000-3-3:1995 con A1:1998 – Fluctuaciones de voltaje y centelleo.

73/23/EEC Directriz de bajo voltaje EN 61010-1:1993 con A1:1995 Requisitos de seguridad de equipo eléctrico para medición, control y uso en laboratorio. Parte 1: Requisitos generales

Jim Boigenzahn
Name of Authorized Representative

Winona, Minnesota, USA
Place of Issue

General Manager
Title of Authorized Representative

September, 2001
Date of Issue

Signature of Authorized Representative

Series 97 Software Map

Home Page

97 Process Value
SAFE Limit Status

Operations Page

LIM Limit Menu

OPER Operations Page
LLo Low Limit Set Point
Lh High Limit Set Point
CAL Calibration Offset

MON Monitor Menu

OPER Operations Page
Pr1 Process 1
LSE Limit Status
AL2 Alarm 2 Status
AL3 Alarm 3 Status
AL4 Alarm 4 Status
ESI Event Input Status

ALM Alarm Menu

OPER Operations Page
ALLo Alarm 2 Low
ALHi Alarm 2 High
ALLo Alarm 3 Low
ALHi Alarm 3 High
ALLo Alarm 4 Low
ALHi Alarm 4 High

Enter your settings on a photocopy of this page.

Setup Page

INP1 Input 1 Menu

SEE Setup Page
SEN1 Sensor Type 1
IN1 Input 1
RL1 Range Low 1
Rh1 Range High 1
DEC1 Decimal 1
FERR Input Software Filter 1

INP2 Input 2 Menu

SEE Setup Page
IN2 Input 2
EFN Event Function
ECN Event Condition

OUT1 Output 1 Menu

SEE Setup Page
LSID Set Limit Active Sides
LHYS Limit Hysteresis

OUT2 Output 2 Menu

SEE Setup Page
OUT2 Output 2
HY52 Alarm Hysteresis 2
LAE2 Latching 2
SIL2 Silencing 2
SID2 Alarm Active Sides 2
LOG2 Alarm Logic 2
ANU2 Alarm Annunciation 2

OUT3 Output 3 Menu

SEE Setup Page
OUT3 Output 3
HY53 Alarm Hysteresis 3
LAE3 Latching 3
SIL3 Silencing 3
SID3 Alarm Active Sides 3
LOG3 Alarm Logic 3
ANU3 Alarm Annunciation 3

OUT4 Output 4 Menu

SEE Setup Page
OUT4 Output 4
HY54 Alarm Hysteresis 4
LAE4 Latching 4
SIL4 Silencing 4
SID4 Alarm Active Sides 4
LOG4 Alarm Logic 4
ANU4 Alarm Annunciation 4
ANOUT Analog Output 4
PRC4 Process 4 Type
AH Analog Output High
ALO Analog Output Low
ARAL Analog Output Offset
BAUD Baud Rate
ADDR Address

DISP Display Menu

SEE Setup Page
UDSP Upper Display
UPL Upper Display User Limit Message
Ldsp Lower Display
LOS Lower Display User Safe Message
LOL Lower Display User Limit Message

GLBL Global Menu

SEE Setup Page
C-F C or F
ERR Input Error Latching

Factory Page

LOC Lockout Menu

FCEY Factory Page
OPER Operations Page Mode
SEE Setup Page Lock
CAL Calibration Menu Lock

DIR9 Diagnostics Menu

FCEY Factory Page
MDL Model Number
DATE Date of Manufacture
SNI Serial Number 1
S2 Serial Number 2
SOFT Software ID Number
REV Software Revision
IEY2 Input 2 Hardware Enabled
OEY1 Output 1 Hardware
OEY2 Output 2 Hardware
OEY3 Output 3 Hardware
OEY4 Output 4 Hardware
TEUT Test Output
DISP Test Displays
HRES High Resolution
AMB Ambient Temperature
ACNT Ambient A-D Counts
CNT1 Channel 1 A-D Counts
CNT2 Channel 2 A-D Counts
LINF Line Frequency

The Factory Page also includes calibration parameters that are not necessary for everyday use of the controller. Calibration parameters and procedures are explained in the Appendix.

How to Reach Us



Quality and Mission Statement:

Watlow Winona will be the world's best supplier of industrial temperature control products, services, and systems by exceeding our customers', employees', and shareholders' expectations.

Contact

Your Authorized Watlow Distributor is:

- Phone: (507) 454-5300.
- Fax: (507) 452-4507.
- For technical support, ask for an Applications Engineer.
- To place an order, ask for Customer Service.
- To discuss a custom option, ask for a Series 97 Product Manager.

Warranty

The Watlow Series 97 is warranted to be free of defects in material and workmanship for 36 months after delivery to the first purchaser for use, providing that the units have not been misapplied. Since Watlow has no control over their use, and sometimes misuse, we cannot guarantee against failure. Watlow's obligations hereunder, at Watlow's option, are limited to replacement, repair or refund of purchase price, and parts which upon examination prove to be defective within the warranty period specified. This warranty does not apply to damage resulting from transportation, alteration, misuse, or abuse.

Returns

- Call or fax Customer Service for a Return Material Authorization (RMA) number before returning a controller.
- Put the RMA number on the shipping label, and also on a written description of the problem.
- A restocking charge of 20% of the net price is charged for all standard units returned to stock.

Watlow Series 97 User's Manual